

HM Collamat AG  
Pfeffingerring 201  
CH-4147 Aesch  
Switzerland

Phone +41 61 756 28 28  
Fax +41 61 756 29 29  
contact@collamat.ch  
www.collamat.ch

# **Collamat 6600**

## Technical handbook

<b>Index</b>	<b>page</b>
1 Safety advices .....	4
1.1 Important Warnings .....	4
1.2 Danger Indications .....	4
1.3 Symbol descriptions .....	5
2 Introduction .....	6
2.1 General informations .....	6
2.2 The labeler C6600 .....	6
2.2.1 Prevention of accidents .....	7
2.2.2 Noise suppression .....	7
2.2.3 Mechanical stability .....	7
2.3 Assembly parts .....	8
3 Mechanical adjustments .....	9
3.1 Traction unit .....	9
3.1.1 Threading the labelweb .....	9
3.1.2 Adjustment of rewinder coupling force .....	9
3.1.3 Readjustment of paper brake .....	10
3.1.4 Longitudinal adjustment on the module rail .....	10
3.2 Flap adapter .....	11
3.2.1 Inclination adjustment of flap adapter .....	11
3.2.2 Adjustment of the pressure roller of the flap adapter .....	11
3.3 Adjustment of the optical label scanner .....	12
3.4 Adjustment of the mechanical label scanner .....	13
4 Technical description .....	14
4.1 Dispenser board .....	14
4.1.1 Power supply .....	14
4.1.2 Motordriver .....	14
4.1.3 Controller .....	14
4.2 Signals and connection diagrams .....	15
4.2.1 Inputs .....	16
4.2.2 Outputs .....	16
4.2.3 Isolated outputs .....	17
4.2.4 Open-Collector-outputs .....	17
4.2.5 Currentsource-output .....	18
4.3 Connection diagrams BUS X101, X102 .....	19
4.4 Transformer wiring .....	19
4.5 Connection of the mains input .....	20
4.6 Grounding of the labeler .....	20
4.7 Connection of the mains output .....	21
4.8 Connection of the frontpanel .....	21

<b>Index</b>	<b>page</b>
4.9 Motor and motorcable .....	22
5 Firmware .....	23
5.1 Normalmode .....	23
5.2 DIL-switches .....	24
5.2.1 DIL-switch TEST .....	24
5.2.2 DIL-switch DIR .....	24
5.2.3 DIL-switch DEL .....	25
5.2.4 DIL-switch NS .....	25
5.2.5 DIL-switch R1 .....	25
5.2.6 DIL-switch R2 .....	25
6 Trouble shooting .....	26
6.1 Fuses .....	26
6.2 Status LEDs .....	26
7 Peripheral units and sensors .....	27
7.1 Optical label scanner .....	27
7.2 Goods scanners .....	27
7.2.1 CS measuring IR-scanner .....	27
7.2.2 NPN-Reflective scanner .....	27
7.3 Magnet adapter .....	28
7.4 Flatprinting unit .....	29
7.4.1 Flatprinter board .....	29
8 Control signals for external units .....	30
8.1 How to connect a goods scanner .....	30
9 Electrical installation .....	31
9.1 Introduction .....	31
10 Nonstop labelling .....	33
10.0.1 Setting up of the Nonstopmode .....	34
11 Testmode .....	35
11.1 Testprogram .....	36
11.1.1 Motortest .....	36
11.1.2 Motor intervall test .....	37
11.1.3 BUS-signal selftest .....	37
11.1.4 Signal display .....	38
11.1.5 DIL-switch settings .....	38
11.1.6 Potentiometer settings .....	38
11.1.7 EEPROM Data .....	39
11.1.8 Version and Serial-No .....	39
11.2 Potentiometer parameters .....	39
11.3 Incremental encoder programming .....	41

<b>Index</b>	page
12 Incremental encoder .....	43
13 Control of a hotstamp with the IFEED signal .....	44
14 Cabling and setting up .....	45
14.1 Cabling .....	45
14.2 Setting up .....	45
15 Version numbers .....	46
16 Glossary and terms .....	46
16.1 Short cuts .....	46
16.2 Signals .....	46
16.3 Terms .....	47
17 Technical data .....	48
17.1 Dimensions - systemdesign .....	50
18 Trouble shooting .....	51
18.1 Trouble shooting Collamat 6600 .....	51
18.2 Trouble shooting checklist .....	56
Appendix spare parts Collamat 6600	

# 1 Safety advices

## 1.1 Important Warnings



Before installing and operating the Collamat 6600 read following safety instructions:

- The labeler C6600 is exclusively determined for labelling goods.
- The installation of a Collamat 6600 has to be done by a trained specialist.  
For this you have to consider the national specific regulations of
  - prevention of accidents
  - mechanical stability
  - construction of electrical and mechanical systems
  - noise suppression
- Take notice to the technical data of the Collamat 6600. Especially the environment conditions must be observed.
- The operation of the Collamat 6600 must be done by trained personnel.
- In case of non-authorized modification guarantee will fall.
- Before connecting non-standard products ask your competent technical supporter.

## 1.2 Danger Indications

- The safety symbols and danger advices on the Collamat 6600 and in this manual must strictly be observed.
- Before connecting or disconnecting the labeler to or from the mains, it must be switched off.
- The labeler C6600 may only be opened by authorized personnel.
- Before opening the labeler C6600, it must be separated from the mains power.
- It exists danger of pinching hairs, jewelry, ties, clothes etc. into the traction unit
- It exists danger of injury by cutting fingers in the area of the paper web.
- It exists danger of injury in the area of the dancer of the unwinder of the Collamat 6600.
- It exists danger of injury in the area of the paper stockcontroller of the Collamat 6600.
- For operation on the Collamat 6600 the operating personnel must keep to a safely place to prevent injury from the products being labeled.

### 1.3 Symbol descriptions



**ATTENTION**

Indicates danger of damaging the Collamat 6600 or other system components, with a potential consequential danger of injuries.

**DANGER**

Indicates an immediate hazard for persons.

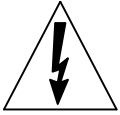

**DANGER**

Shock hazard due to high voltage at component.

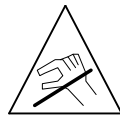

**DANGER**

Hazard due to high temperature component.



**ATTENTION**

ESD warning (Electro Static Discharge). The PC boards or component may only be touched in an electrostatically protected environment.

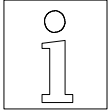

**NOTE**

Important or additional information to Collamat 6600 or to the documentation.

## 2 Introduction

### 2.1 General informations

This technical handbook describes the construction and the function of the Collamat 6600. In addition to the operating instructions, it contains the necessary tips and adjustments to get optimum use of the Collamat 6600. The descriptions of each electrical or mechanical device also helps for quick error analysis and error elimination.

We recommend you to replace the complete electronic boards. Return it to HM Collamat AG or to its representative for repair. You can then feel sure, that the high quality standard of the Collamat 6600 can also be guaranteed after repair.

### 2.2 The labeler C6600

Special characteristics of the Collamat 6600:

- resistant to wear, no clutch/brake-system
- robust, stable
- easy installation and operation due to the modular construction
- quick change-over to other labelling tasks
- high performance
- high reliability
- latest SMD-technology
- high precision 2-phase stepper motor

The traction unit as well as the other peripheral assemblies are mounted on a modular rail. The control electronics of the peripheral units are built in the units. The units are controlled and driven by signals of the bussystem inside of the modular rail.

The operating elements for dispensing speed, predispensing, position, optical label scanner, data-hold switch, as well as the mains switch are placed right on the body of the traction unit itself. All parts are corrosion-proof, the feedroller of the traction unit is provided with a special coating for permanent nonslip torque transmission onto the paperweb. The rewinding force of the rewinder as well as the braking power of the paper brake are adjustable at the traction unit from the outside.

The installation of the Collamat 6600 must be done by trained personnel. For this you have to consider the national specific regulations of:

- prevention of accidents
- noise suppression
- mechanical stability
- construction of electrical and mechanical systems

### 2.2.1 Prevention of accidents

While installing and connecting the Collamat 6600 take care that the signal cables and power cables can't become obstacles. The cables must be placed and installed according to the national safety requirements. Take care that the signal cables are not placed beneath power cables. The mains switch and the control elements must be easily accessible.

### 2.2.2 Noise suppression

The dispenser C6600 is shielded according to the CE directives. Only cables which are certificated by HM Collamat AG may be used for connecting the dispenser to the peripheral units and the mains power. Additional peripheral units must be connected to the auxiliary mains terminal of the dispenser. These assemblies must be certificated by HM Collamat AG.

### 2.2.3 Mechanical stability

If the Collamat 6600 is used on a movable stand, this stand must be capable to be tilt 10° in each direction. See also following figure 1:

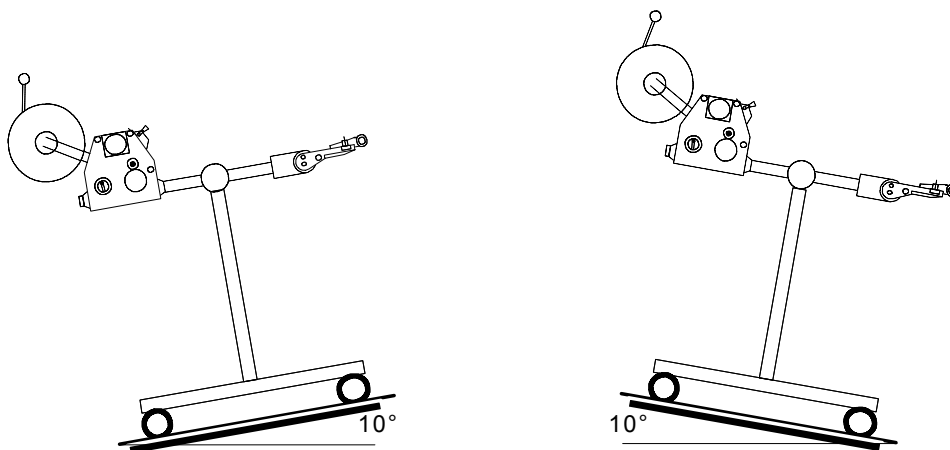

Figure 1: Stability of the stand

## 2.3 Assembly parts

The assembly parts are mounted and placed on a modular rail. Following figure 2 shows these assembly parts with their names on the modular rail:

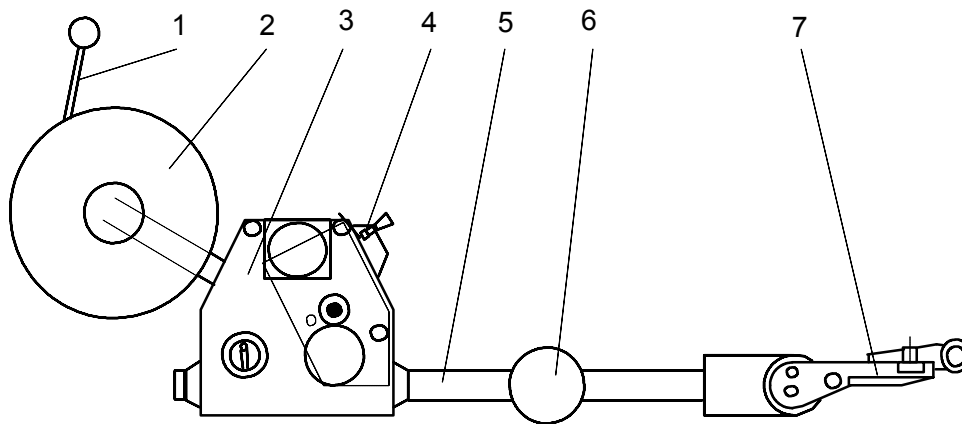

Figure 2: Assembly parts

### Legend

- |                    |                                   |
|--------------------|-----------------------------------|
| 1. Unwinder dancer | 5. Modular rail                   |
| 2. Unwinder        | 6. Support                        |
| 3. Traction unit   | 7. Adapter (optional with magnet) |
| 4. Paper brake     |                                   |

### 3 Mechanical adjustments

#### 3.1 Traction unit

##### 3.1.1 Threading the labelweb

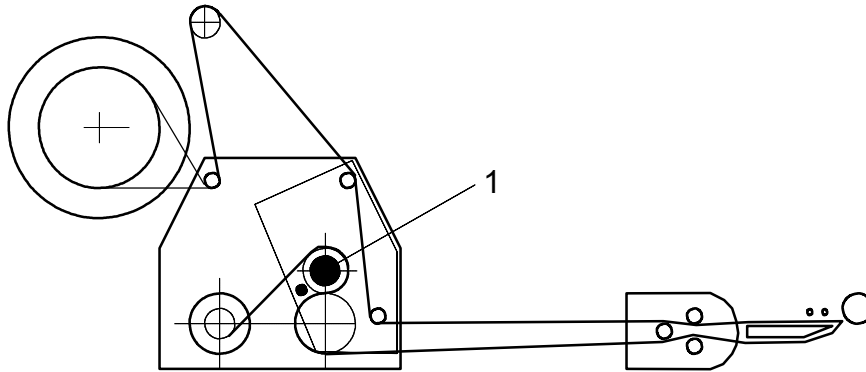

Figure 3

Thread the labelweb as shown in figure 3 up to the dispensing edge and draw it out by approx. 1m. Detach the labels from the paperweb at the drawn-out web. Then open the pinchroller by turning the knob **1**, place the paperweb over the dispensing edge and finish threading the paperweb as shown in figure 3. Close the pinchroller. Adjust the side guides of the paperweb well, leaving 0.5 mm free space to the paperweb's edge.

##### 3.1.2 Adjustment of rewinder coupling force

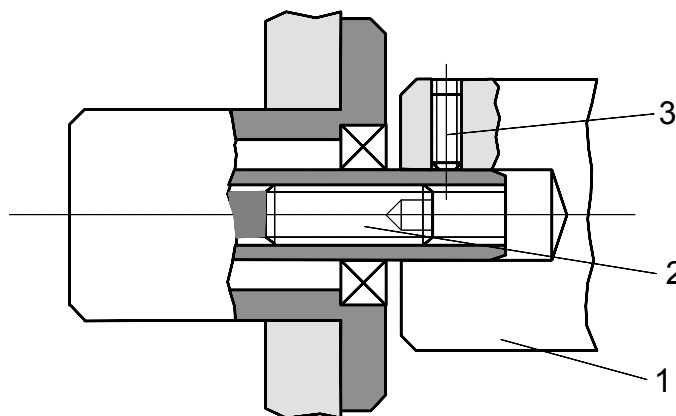

Figure 4

The coupling force of the rewinder is factory-set. Proceed as follows if out of adjustment:  
Detach winding spindle **1** after unscrewing the M5-bolt **3**. Screw M8-bolt **2** accordingly:

- in = harder coupling
- out = softer coupling

### 3.1.3 Readjustment of paper brake

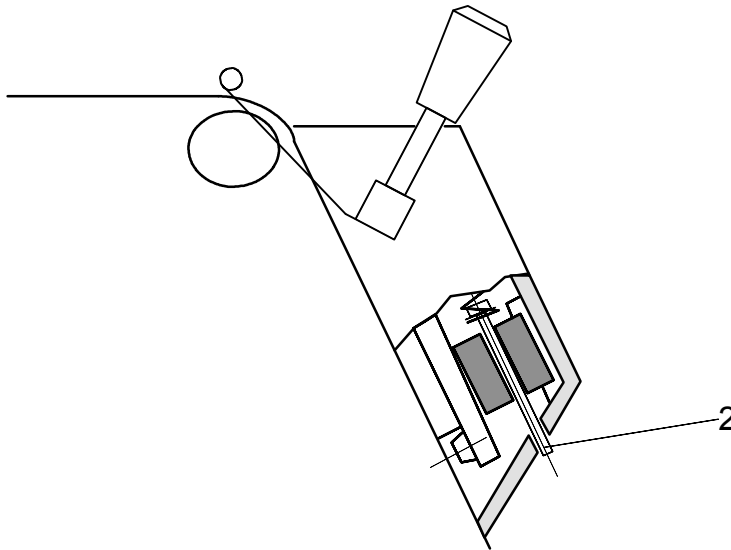

Figure 5

The braking force is factory-set to an optimum value. Should it, however, be unadjusted, readjust it with the M3-bolt **2** in the web-end controlbox of the traction unit, from the outside.

- Screw in bolt = higher braking force
- Unscrew bolt = lower braking force

### 3.1.4 Longitudinal adjustment on the module rail

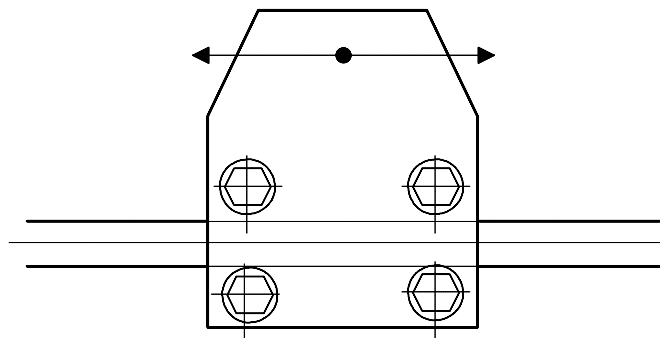

Figure 6

Unscrew 4 bolts with special tool (wrench for socket head cap screws 5 mm) one half turn (adapter only 2 bolts).  
Move device, observing scale on module rail. Then tighten bolts equally.

## 3.2 Flap adapter

### 3.2.1 Inclination adjustment of flap adapter

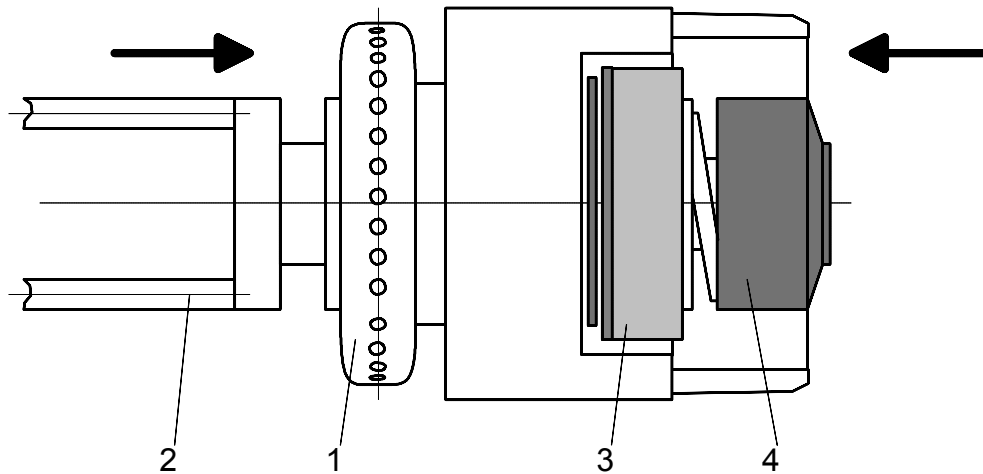

Figure 7

The inclination of the flap adapter can be changed against the module rail: Unscrew nut **1** with two turns (refer to figure 7), with special hexagonal spanner (included as accessory). Push adapter in the direction indicated by the arrow **2**, turn to desired setting at ring **3**. Retighten nut **1**.

The pressure force of the flap adapter without magnet or of the magnetic flap adapter is variable: push in button **4** in the direction indicated by the arrow, twist for appropriate spring tension and adjust until it meets the next stop.

### 3.2.2 Adjustment of the pressure roller of the flap adapter

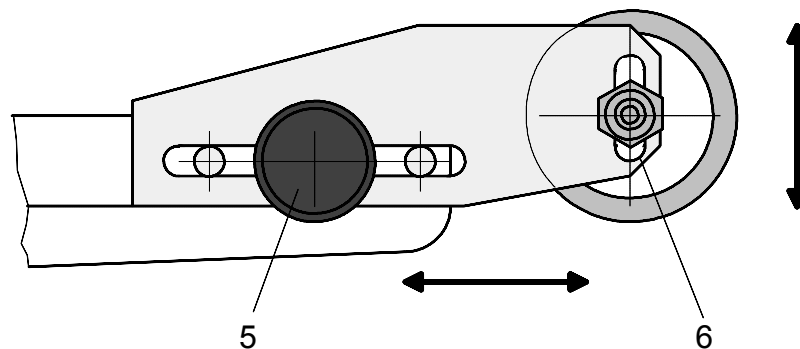

Figure 8

The pressure roller of the adapter can be adjusted depending on the labels and goods:

- Horizontal adjustment with the knurled nut **5**
- Vertical adjustment with the hexagonal nut **6**

### 3.3 Adjustment of the optical label scanner

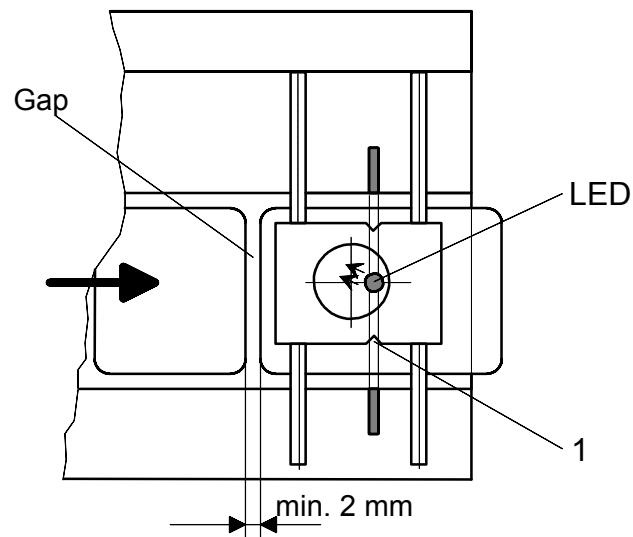
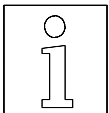

Figure 9

Proceeding of the adjustment of the optical label scanner:

Switch on the Collamat 6600. Set the label scanner potentiometer to zero. Pull the labelweb so that the gap is located below the marking **1** of the scanner. Turn the potentiometer until the red LED on the scanner goes off. Continue pulling the labelweb until a label is located below the scanner. Continue turning the potentiometer until the LED switches off again. The optimum setting is at the center position of the two potentiometer settings witch turned the LED off.



**Remark:**

**If the setting of the optical label scanner is faulty, the gap between the labels will not be detected. After the triggering of a labelling operation, the labeler will stop after approx. 0.75 m of the labelweb.**

**For transparent labels, please use the mechanical label scanner.**

### 3.4 Adjustment of the mechanical label scanner

The mechanical label scanner (not used on magnetic flap adapter) is an alternative to the optical label scanner and is mainly used for transparent labels.

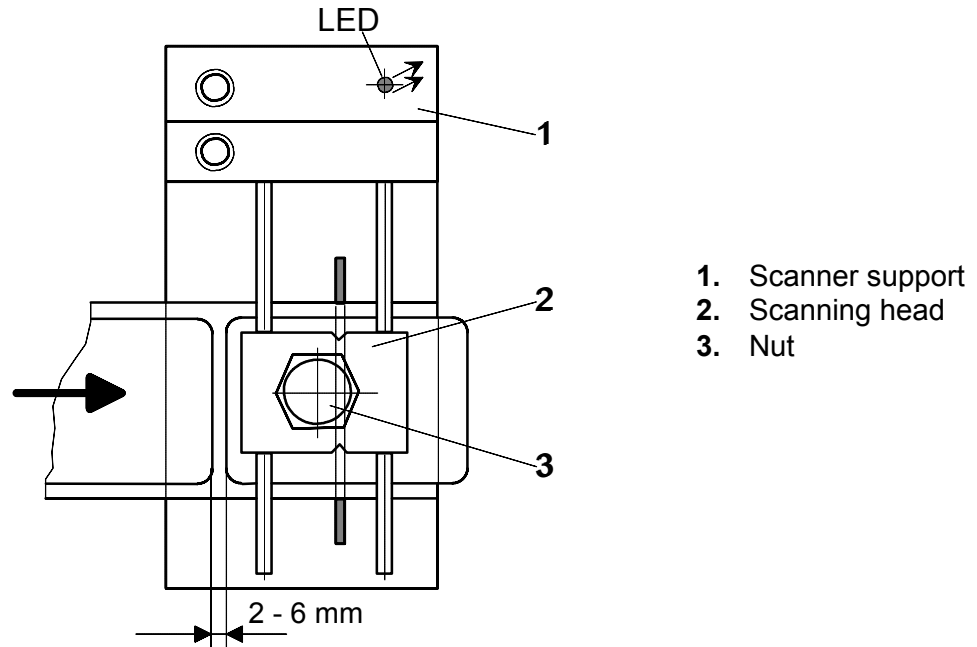
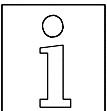

Figure 10

#### Adjustment:

- Place the label under the scanning head, the LED on the scanner support must be turned on. If this is not the case, unscrew the nut on the scanning head and turn it counterclockwise until the LED turns on.
- Turn the scanning head clockwise until the LED turns off.
- Turn the scanner one quarter turn forward and retight the nut.
- Place the gap between the labels under scanning head, the LED-display must be turned on.



**Note:**  
**No adjustment is necessary on the traction unit!**

## 4 Technical description

### 4.1 Dispenser board

All the electronic devices including power transformer, except of the main switch with indicator lamp, are located on a printed board. The dimensions of the board are approximately 215 x 234 mm. Figure 11 shows the board with all the connectors and terminals.

The description is divided into power supply, motordriver, controller and firmware.

#### 4.1.1 Power supply

The power supply unit generates the two regulated voltages +12V/1A and + 5 V/1A for the logic, as well as an unregulated DC voltage of approx. 70V/3.5A for the stepper motor. The stabilization is done by linear voltage regulators.

#### 4.1.2 Motordriver

The driver board consists of 2 H-bridge circuits to drive the two motor phases. The phase current is 4 A while running, and 2 A when stopped. To control the current, a chopper circuit with 20 kHz chopper-frequency is used.

Dependent on the dispensing speed the processor generates a fullstep- or a halfstep pattern. For speeds faster than 8 m/min, the motor is driven by a fullstep-pattern.

In the case of overheating, short-circuit or malfunction the motordriver is switched off and the red LED **FAULT** is illuminated. In this case the labeler must be switched off and on again. If a faulty condition is detected, the signal **ERROR** is activated.

#### 4.1.3 Controller

The single chip micro-controller H8/532 with external 32 K-Byte EPROM controls the functions of the labelling process.

- All outputs are buffered by photo-couplers.
- All the inputs are pulled up to +12V with 2.2 K and are equipped with a low-pass filter.
- The A/D-converter scans periodically the value of the settings of the 4 potentiometers (R101....R104).
- The control current of the label scanner is generated by a controlled current source.
- The data, stored when DATA-HOLD is activated, are stored in a 256 bit EEPROM.

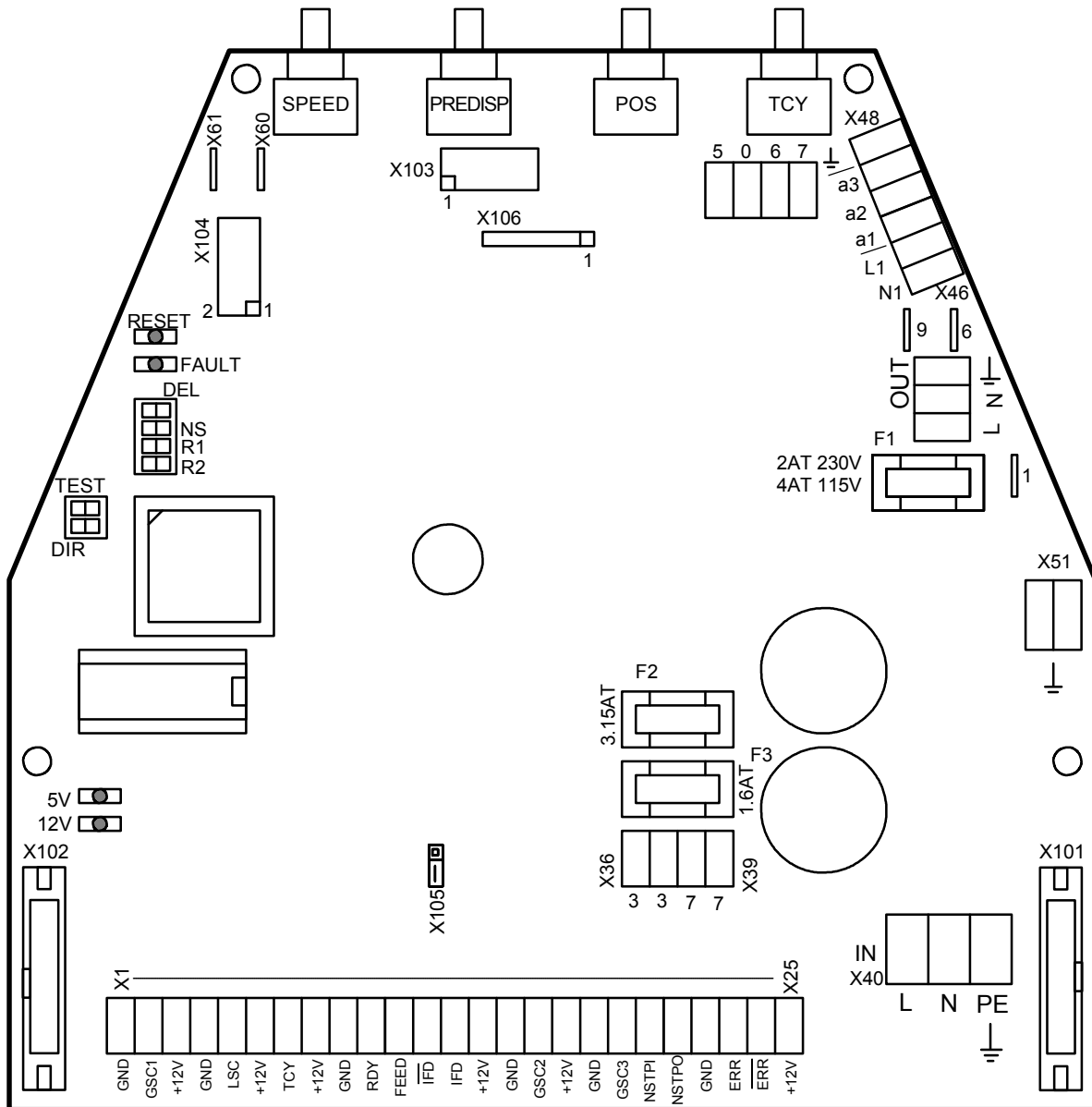

Figure 11: Dispenser board

## 4.2 Signals and connection diagrams

All in- and outputs are equipped with filter elements to prevent electromagnetic interference. These components also prevent interference caused by electrostatic discharge. The interference can lead to malfunction of the Collamat 6600. Anyway, installing the Collamat 6600 you have to consider the rules concerning RMI and ESD to prevent these interferences. See also chapter **Cabling**.

## 4.2.1 Inputs

The inputs are used to connect peripheral units and sensors. The inputs are activated while they are pulled to GND (0 Volt). The peripheral units from HM Collamat AG have NPN-outputs to 0 Volt. Figure 12 shows the schematic diagram of the inputs:

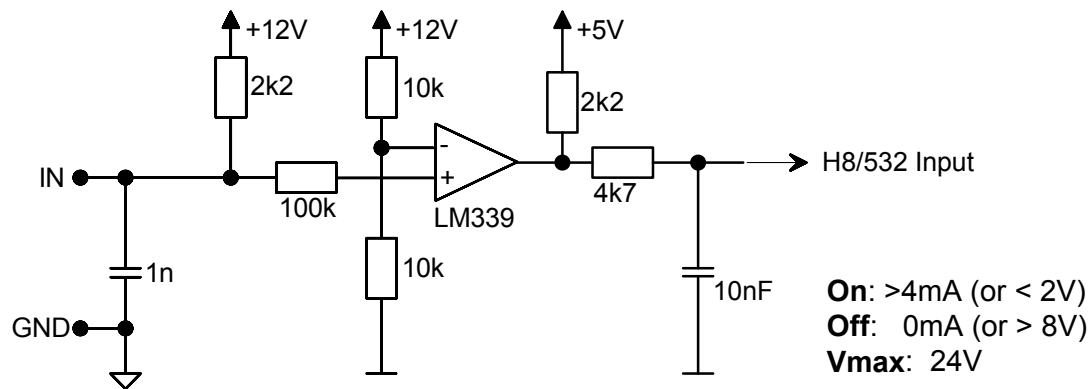

Figure 12: Signal input

An input is then active, when a current of minimum 4mA is pulled to GND. The following inputs are available:

- **GSC1** Goods scanner
- **GSC2** Incremental encoder input
- **GSC3** Goods scanner for counting in the Nonstop-mode
- **LSC** Label scanner
- **READY** READY-signal for peripheral units
- **NSTPI** Nonstop-input, (Controlsignal), (equal to RESIN)

## 4.2.2 Outputs

The outputs are used to control peripheral units. There are three different kinds of outputs:

- **Isolated outputs**
- **Open-Collector-outputs**
- **Currentsource-output**

### 4.2.3 Isolated outputs

These outputs are completely isolated to the electronic circuit of the labeler. Figure 13 shows the schematic diagram of the isolated outputs. The following outputs are available:

- **ERROR** Photocoupler, indicates an error condition (ERR)
- **IFEED** Photocoupler, isolated FEED-signal (IFD)

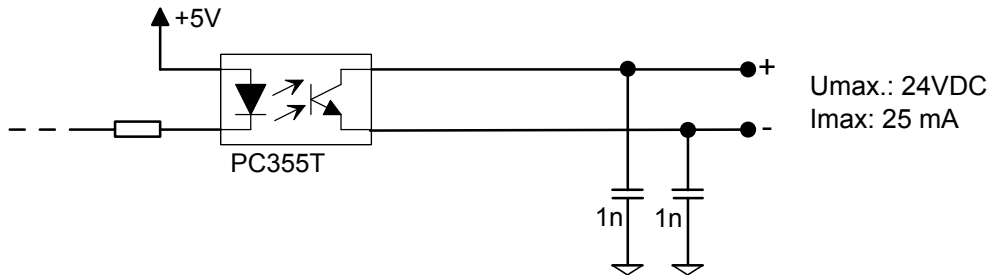

Figure 13: Isolated outputs

### 4.2.4 Open-Collector-outputs

For better resistance against interferences, the Open-Collector-outputs are also equipped with photocouplers. Figure 14 shows the schematic diagram of the Open-Collector-outputs. The following Open-Collector-outputs are available:

- **FEED** Indicated that the motor is turning
- **CLOCK** Steppermotor clock for synchronizing external units
- **NSTPO** Nonstop-output (controlsignal), equal to RESOUT

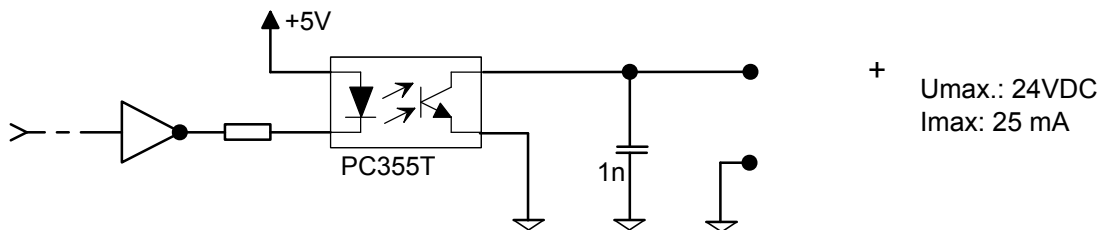

Figure 14: Open-Collector-outputs

### 4.2.5 Currentsource-output

For the IR-transmitter of the label scanner TCY, a controlled currentsource is used. Figure 15 shows the schematic diagram of the currentsource:

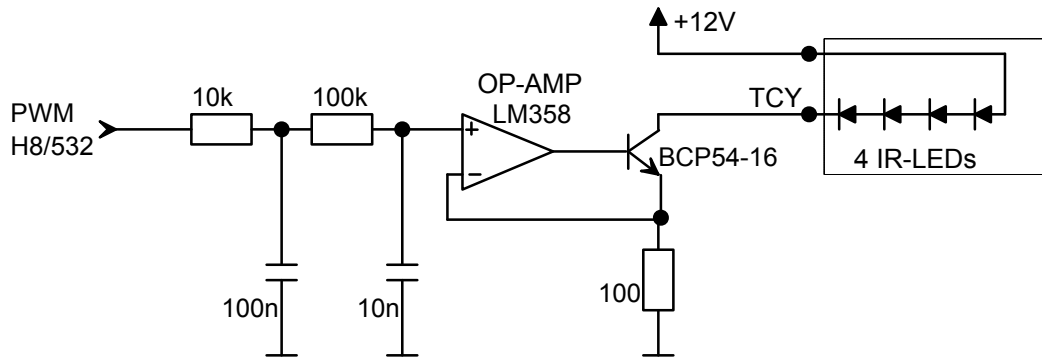

Figure 15: TCY-currentsource

### 4.3 Connection diagrams BUS X101, X102

The buscable of the peripheral units is connected to the connectors X101 or X102. The cable must be placed inside of the module rail to prevent interferences. Figure 16 shows the position of the buscable connectors on the dispenser board:

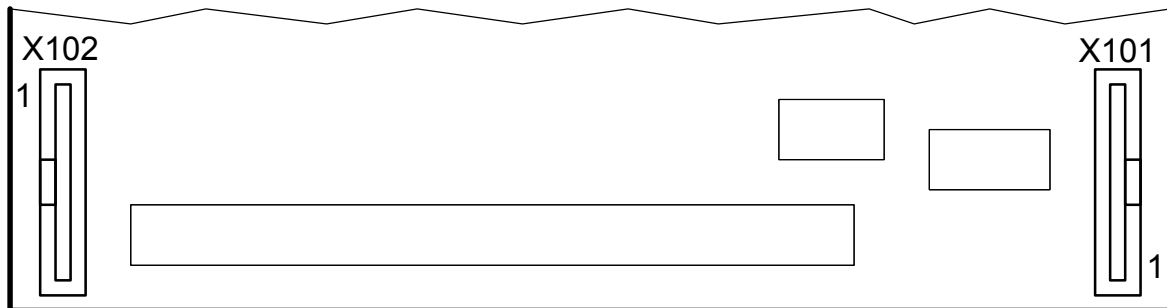

Figure 16

Connector X102			
Pin	Signal	Pin	Signal
1	+12V	2	+12V
3	READY	4	FEED
5	LSC	6	GSC1
7	TCY	8	GSC2
9	nc.	10	CLOCK
11	nc.	12	nc.
13	GND	14	GND

Connector X101			
Pin	Signal	Pin	Signal
1	GND	2	GND
3	nc.	4	nc.
5	CLOCK	6	nc.
7	GSC2	8	TCY
9	GSC1	10	LSC
11	FEED	12	READY
13	+12V	14	+12V

### 4.4 Transformer wiring

The secondary side of the transformer is connected to the terminals X36...X39. Both **violet** wires are connected to the terminals signaled with a **7**. Both **orange** wires are connected to the terminals signaled with a **3**. See also Figure 17:

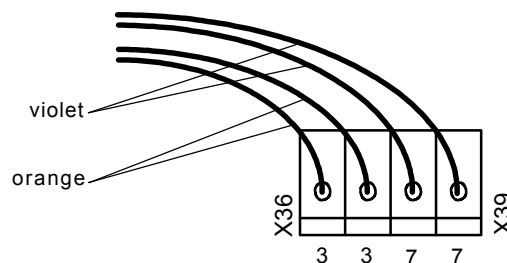

Figure 17

The primary side of the transformer is connected to the terminals X46 and X48. Dependent to the mains voltage the transformer is connected as shown in figure 18:

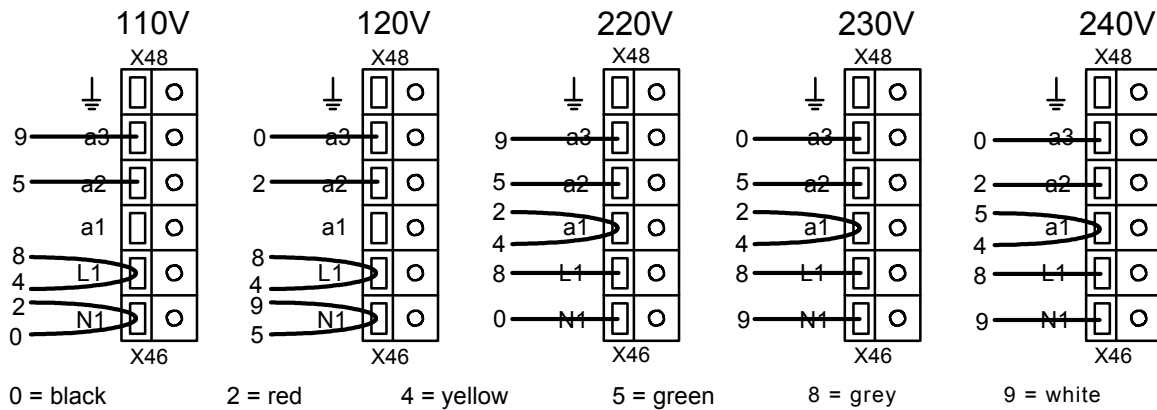

Figure 18: Transformer wiring

#### 4.5 Connection of the mains input

The powercord must be connected to the terminal X40. To prevent interferences it must be looped through a ferrite-filter as shown in figure 19:

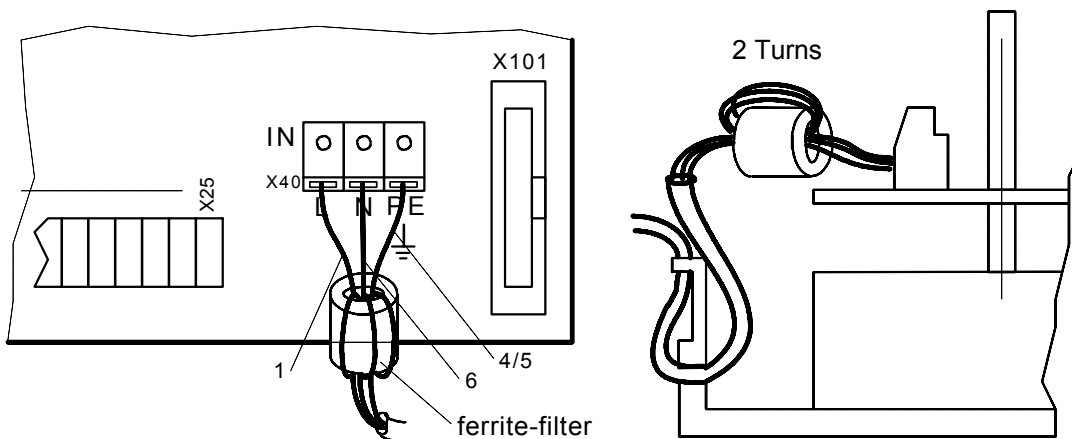

Figure 19

#### 4.6 Grounding of the labeler

The grounding of the module rail and of the adapter must be done to terminal X51. For this see also figure 21.

## 4.7 Connection of the mains output

Peripheral units like the flatprinter or the adapter with magnet are connected to the mains output. To this terminal only units, certified by HM Collamat AG, may be connected. Figure 20 shows the mains output terminal:

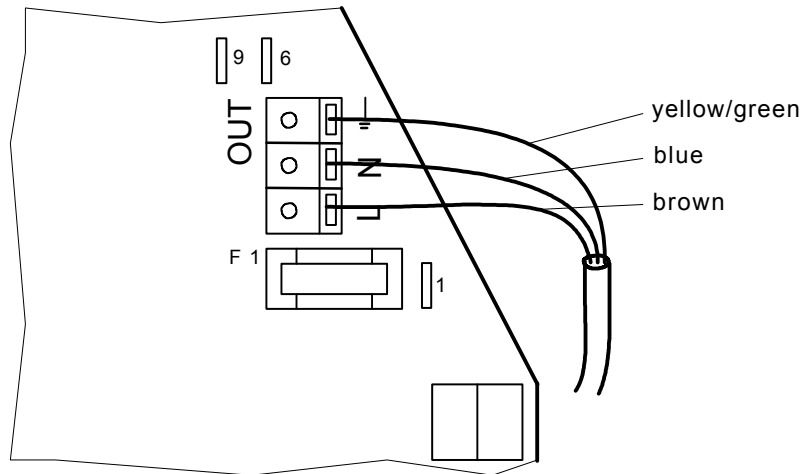

Figure 20

## 4.8 Connection of the frontpanel

The frontpanel must be connected as shown in figure 21:

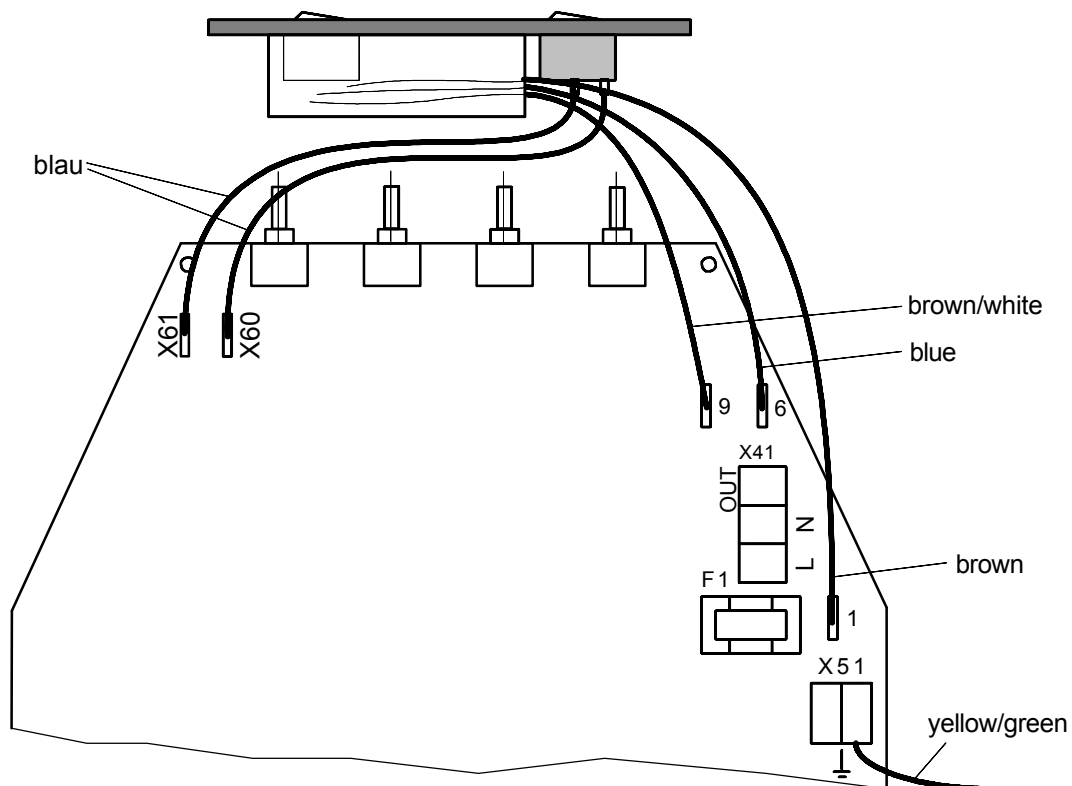

Figure 21

## 4.9 Motor and motorcable

**Attention:**

- **The motor never must be dismantled !**
- **Steppermotor heats up during operation !**
- **When connecting or disconnecting the motor, the labeler must be switched off !**
- **While working on the motor, the labeler must be disconnected from mains !**

The motor is connected inside of the labeler. The motorcable is lead through the hole in the middle part of the board. The wires are connected to the terminals X30...X33. See also figure 22:

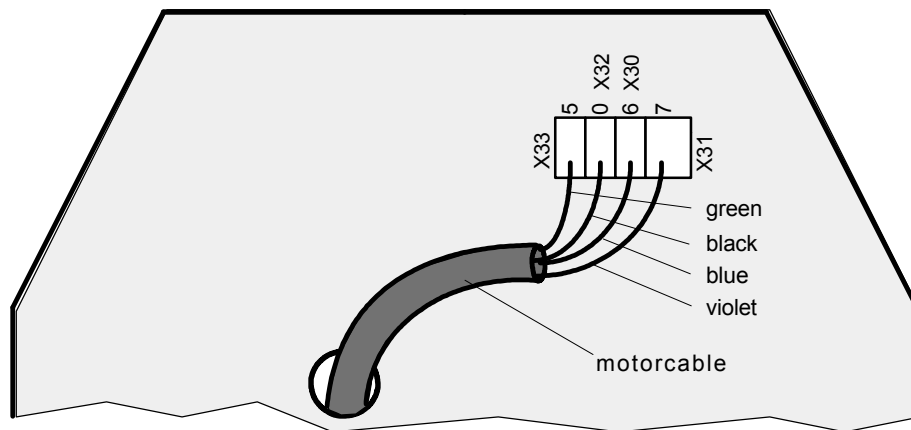

Figure 22: Motor connection

## 5 Firmware

### 5.1 Normalmode

After turning on the labeler, the DIL-switches are scanned to figure out the working mode. Then the DATA-HOLD-switch is scanned. Dependent to its position the data from the EEPROM are read out or the potentiometers are scanned.

The dispensing of a label is triggered by the negative edge of GSC1 (Goods scanner input). READY must not be active (12 Volt). The stop of the labelling is triggered by the detection of the gap (LSC) and performing the remaining steps for the predispensing. The timing diagram of the signals is shown in figure 23:

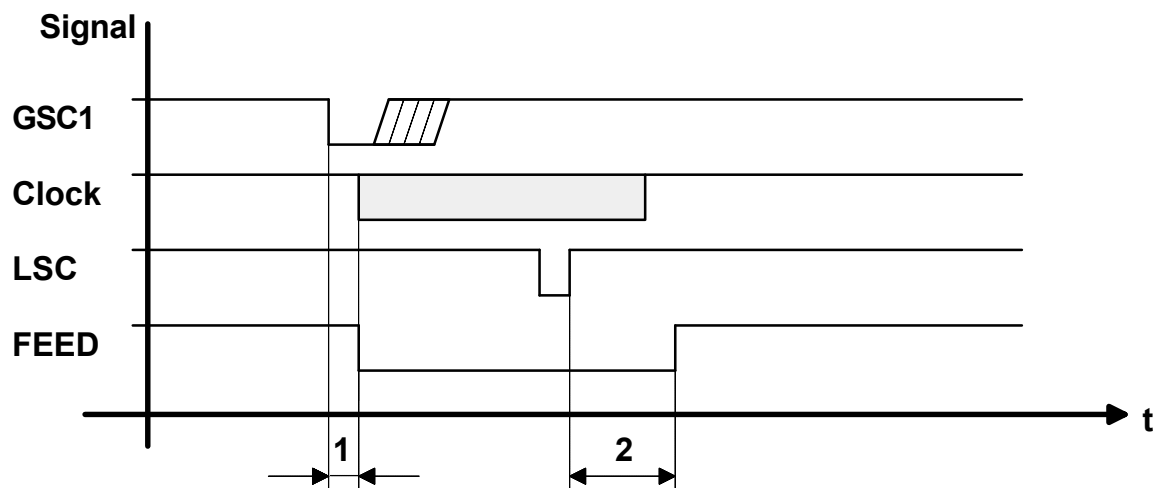

Figure 23: Timing diagram of the GSC1, LSC and FEED signals

1. Speed dependent position delay
2. Length of the predispensing

If the predispensing is increased, it is executed immediately. If it is reduced, it is executed after dispensing the next label.

To generate the holding torque, the motor is powered all the time.

If, for any reason, no negative edge is detected on the LSC-input, the labelweb is automatically stopped after approximately 2 meters. Then the signal **ERROR** is activated.

At speeds faster than 10 m/min, the steppermotor is driven in the fullstep-mode. For slower speeds, in the halfstep-mode.

The minimum speed is 3 m/min. The maximum speed is 30 m/min.

## 5.2 DIL-switches

The dispenser board contains six DIL-switches. These switches are used to select different operating modes. The following table and figure 24 show the functions and the positions of the DIL-switches:

Switch	Function	Off	On
TEST	Labelingmode/ Testmode	Labelingmode Slave	Testmode Master
DIR	Turning direction of the motor	Right	Left
DEL	Delayed predispensing	Normal mode	Delayed predispensing
NS	Nonstop	Normal mode	Nonstopmode Test On : <b>Master</b> Test Off : <b>Slave</b>
R1	Position/GSC-Suppression	Position	GSC-Suppression
R2	Potentiometer range Incremental encoder	Normal Off	Programmed Programmed

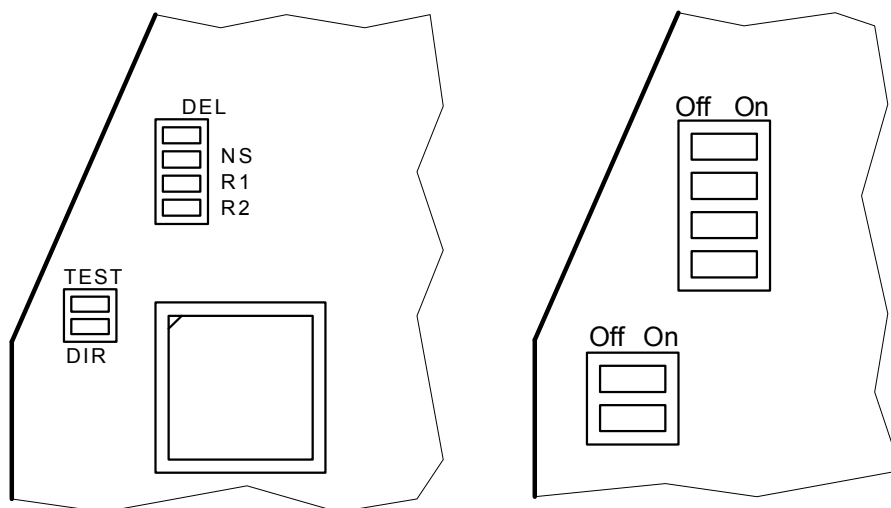

Figure 24: DIL-switches

### 5.2.1 DIL-switch TEST

This DIL-switch selects the testmode. For further informations to the testmode, please read the chapter Testmode.

### 5.2.2 DIL-switch DIR

This DIL-switch selects the turning direction (right or left) of the traction motor.

### 5.2.3 DIL-switch DEL

This DIL-switch selects the mode of delayed predispensing. In this mode, the predispensing is delayed, until the moment when the product has left the goods scanner's position.

### 5.2.4 DIL-switch NS

This DIL-switch selects the Nonstopmode. In the Nonstopmode two Collamat 6600 can be used to work in a zero downtimemode. For further information to the Nonstopmode, please read the chapter **Nonstopmode**.

### 5.2.5 DIL-switch R1

This DIL-switch selects the function of the POSITION-potentiometer. Switched off the potentiometer has the normal POSITION-function. Switched on, the potentiometer is used to adjust a GSC1-suppression. The working range of the suppression then is the same as in the POSITION-mode.

### 5.2.6 DIL-switch R2

This DIL-switch selects the working range of the potentiometers. For further informations, please read the chapter Testmode. The factory setting of the potentiometers is the normal working range. The function of the SPEED potentiometer can be changed in the testmode. If the DIL-switch R2 is switched on, the potentiometer SPEED can be used to fineadjust the steprate of an incremental encoder in the range of  $\pm 10\%$ . The speed is then measured with an incremental encoder. See also chapter **Testmode** and **Incremental encoder**.

## 6 Trouble shooting

### 6.1 Fuses

The Collamat 6600 contains three fuses:

Fuse	Voltage	Value	Part. No.
F1 110V: 230V:	Mains voltage	4AT 5*20mm	74030800
		2AT 5*20mm	74030341
F2	Motordriver 70V	3.15AT 5*20mm	74031216
F3	Logic 12V, 5V	1.6AT 5*20mm	74031135

To exchange the fuses, the cover of the Collamat 6600 must be removed.

If the fuse of the main voltage is blown, the indicator lamp of the power switch is not illuminated when the Collamat is switched on.

If an external peripheral unit like flatprinter or flap adapter is working without any movement of the traction motor, F2 seems to be defective.

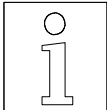

**ATTENTION:**

**If the dispenser board is defective, it must be exchanged. Any repairs or modifications not made by HM Collamat AG will expire the guarantee.**

### 6.2 Status LEDs

The four status LEDs on the dispenser board display show different signals:

LED	Function	Fault
5V	Illuminated, when the 5V for the logic circuit are OK	Fuse F3 or F1
12V	Illuminated, when the 12V for the sensors are OK	Fuse F3 or F1 Short circuit in the sensor supply
RESET	Flashes while turning power on Flash while running	Watchdog RESET Software failure
FAULT	Motordriver supervision	Overheating, short circuit, undervoltage, fuse F2

For trouble shooting, please use the checklist on the last page of the handbook.

## 7 Peripheral units and sensors

### 7.1 Optical label scanner

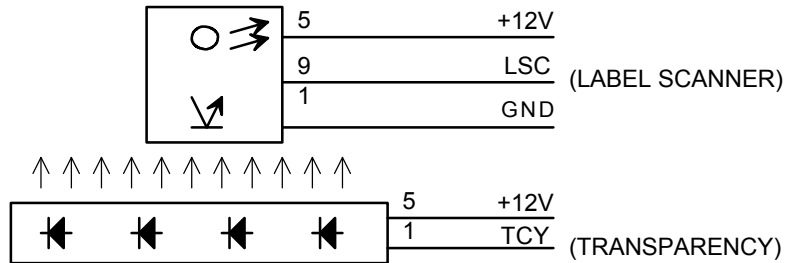

Figure 25

## 7.2 Goods scanners

### 7.2.1 CS measuring IR-scanner

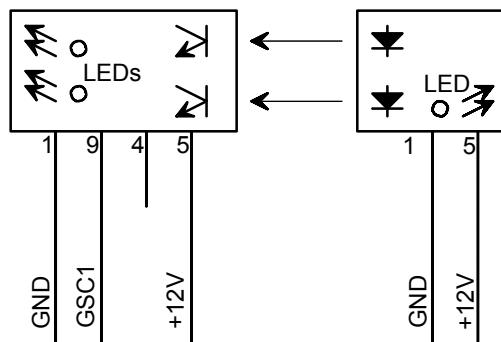

Figure 26

### 7.2.2 NPN-Reflective scanner

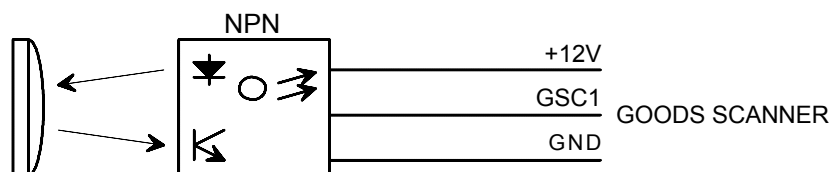

Figure 27

### 7.3 Magnet adapter

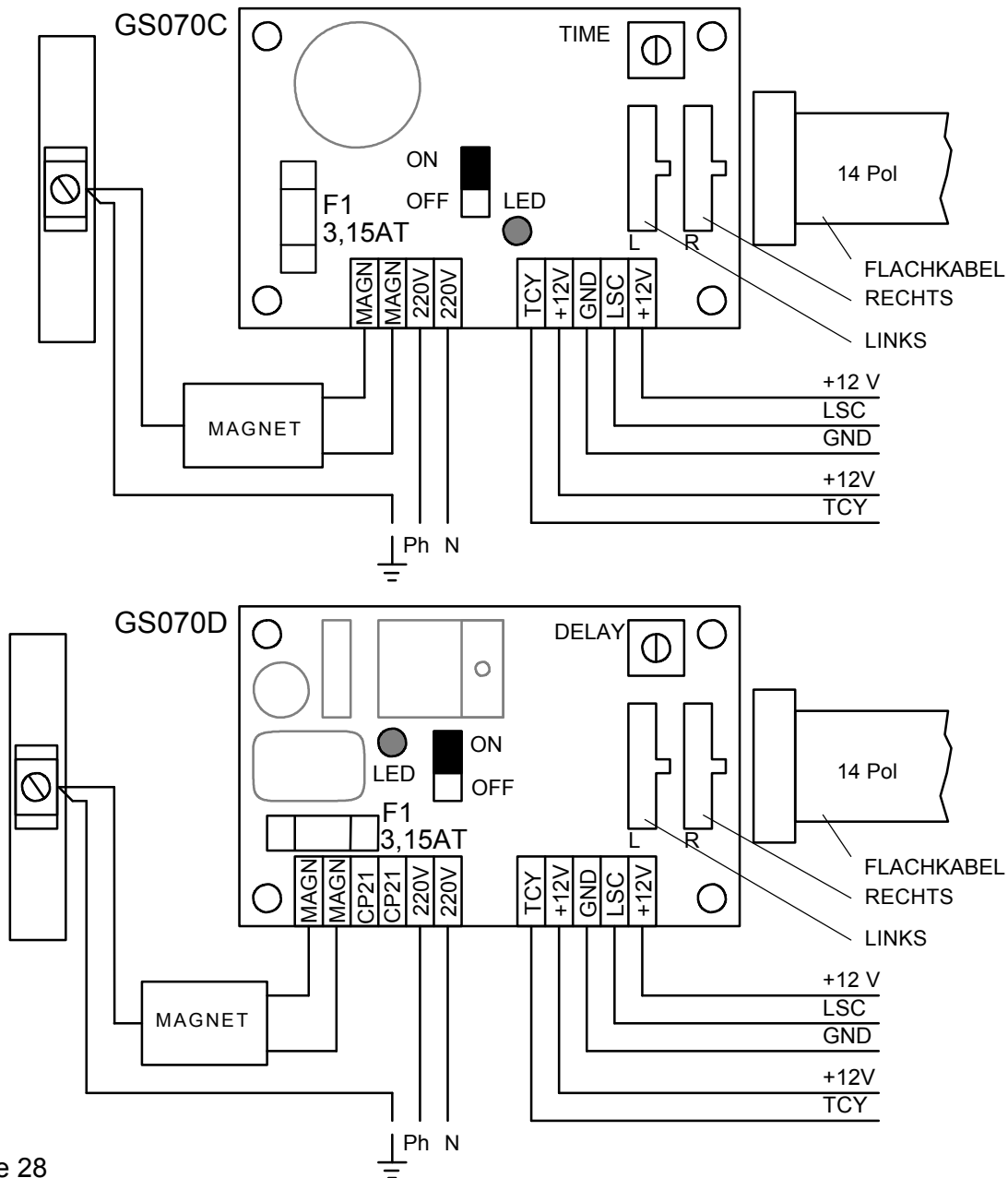

Figure 28

The mains voltage must be connected inside of the flap printer or inside of the dispenser. See also connection diagram figure 33.

The factory setting of the trimmer TIME is on MINIMUM. The trimmer is used to set a delaytime for the releasing of the magnet.

The terminals CP21 are used to connect the synchronous motor of the wrap around adapter



**WARNING:**  
Plugging in of the LEFT or RIGHT connector of the flatcable to the wrong plug can damage the magnet adapter board.

## 7.4 Flatprinting unit

### 7.4.1 Flatprinter board

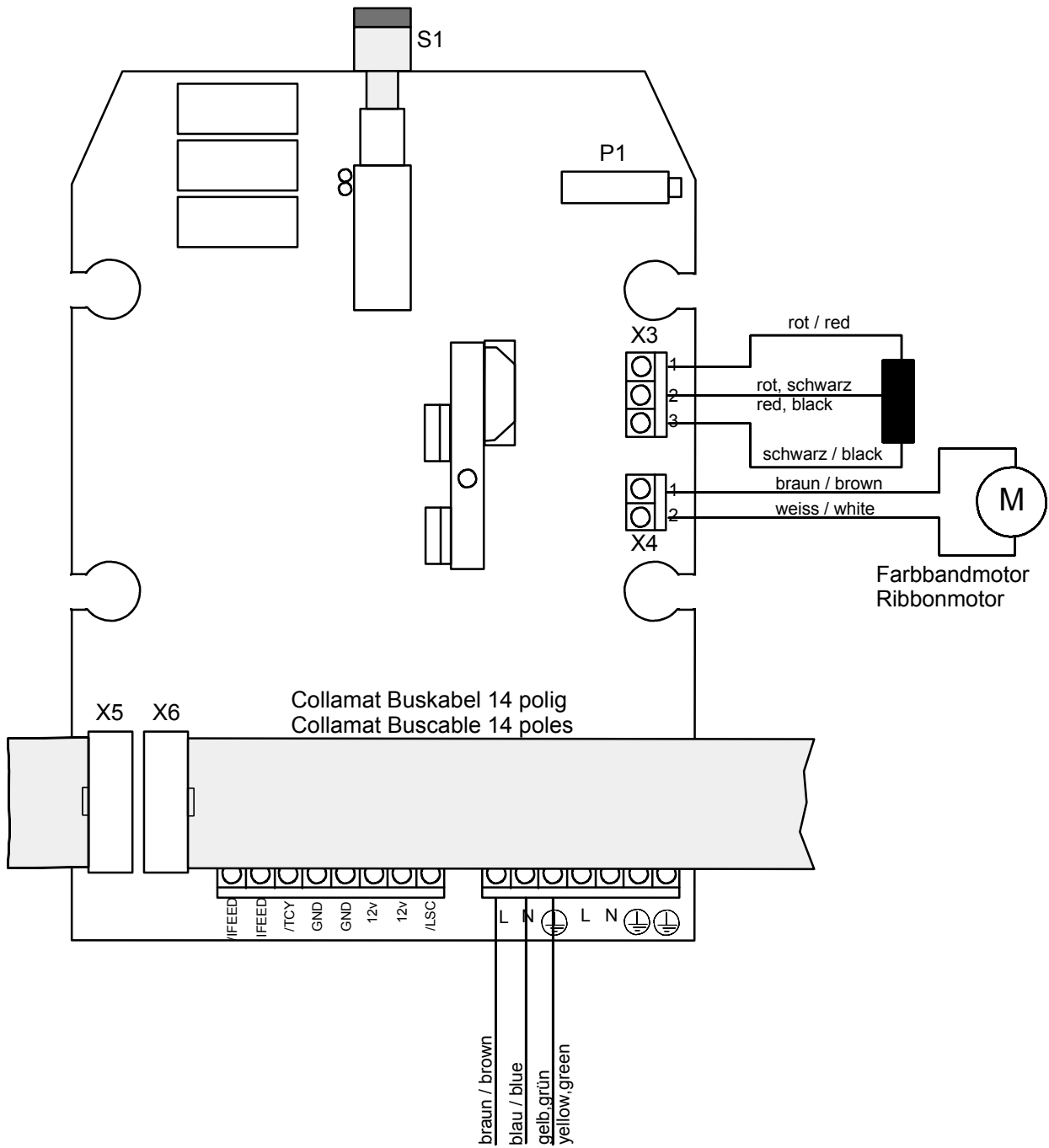

Figure 29

## 8 Control signals for external units

The signals **FEED** and **READY** are used to control external units.

### FEED (Output)

The **FEED** signal indicates that the labeler is dispensing. This means that the stepper motor is turning. With this signal an external flatprinting unit can be controlled. See herefore figure 23.

### READY (Input)

The signal **READY** is used to signal that a connected peripheral device like hotstamp or flatprinter is ready. If the signal is active, this means the NPN-output of the device is pulled to GND, labelling is not possible.

### 8.1 How to connect a goods scanner

The goods scanners and incremental encoders are connected to the GSC1 and GSC2 connectors. Figure 30 shows the connection of the standard HM Collamat AG IR goods scanner:

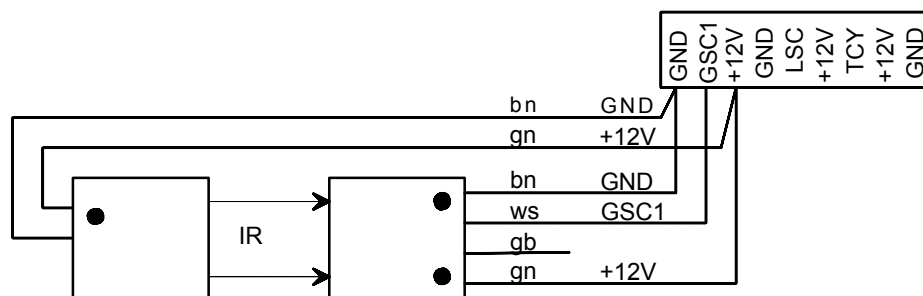

Figure 30: Connection of the CS IR goods scanner

Figure 31 shows the connection of a NPN-scanner:

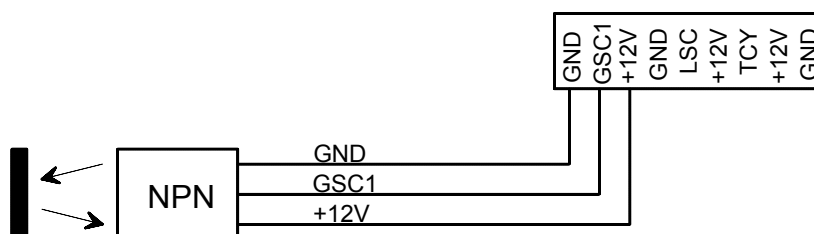

Figure 31: Connection of a NPN-scanner

Figure 32 shows the connection of a NPN-incremental encoder:

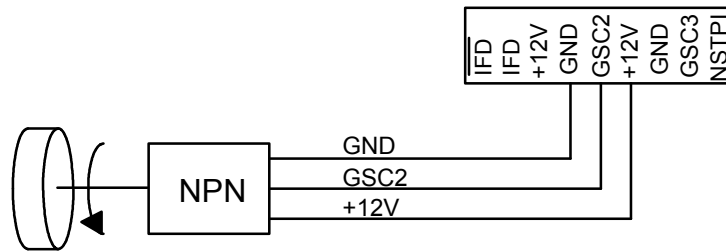

Figure 32: Connection of a NPN-incremental encoder

## 9 Electrical installation

### 9.1 Introduction

The cabling must be done like shown in figure 35. The controlsignals FEED and READY, the supply +12 Volt and ground, are fed through the 14 pole flatcable to the flatprinter and the magnet adapter. An additional 3 pole power cable (3 \* 0.75 mm<sup>2</sup>) feeds the switched mains voltage from the Collamat 6600 to both peripheral units.

The transmitter (2 pole cable) and receiver (3 pole cable) of the optical label scanner can directly be connected to the dispenser C6600, to the flap adapter or to the flatprinter respectively. In this case, the connection to the Collamat 6600 is made by the 14 pole flatcable.

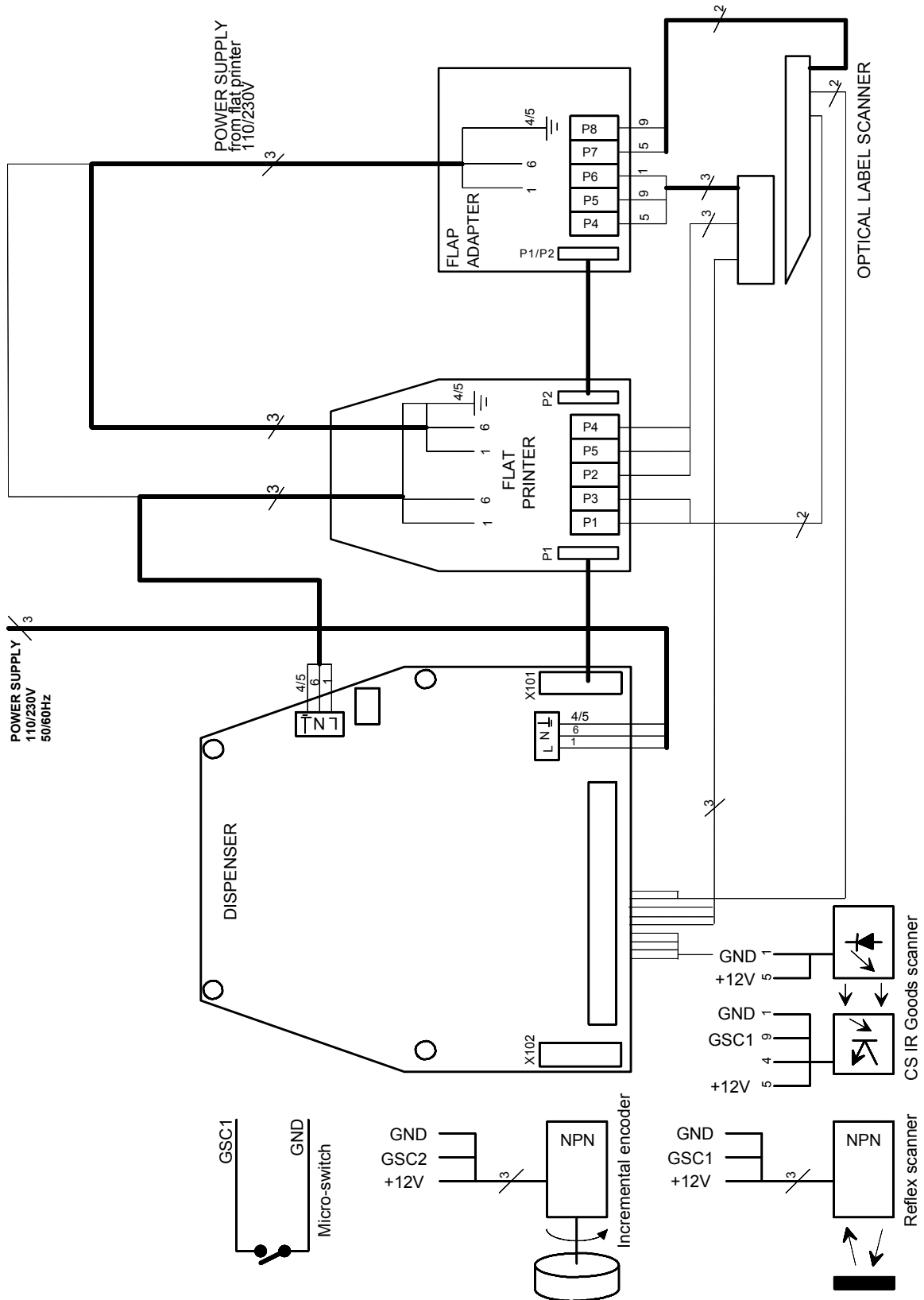

Figure 33: Connection diagram

## 10 Nonstop labelling

When using two Collamat 6600, it is possible to label goods with no down time. For this purpose the two labelers must be connected together by an electrical link. The necessary links are shown in figure 34. The placement of the two Collamat to each other is shown in figure 35.

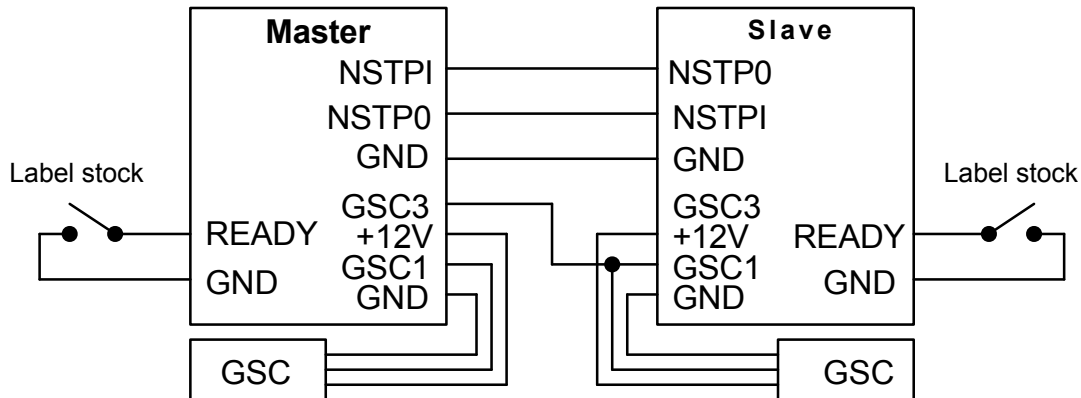

Figure 34: Connections for nonstop labelling

Not shown is the connection of a possible connected speed measuring equipment using an incremental encoder. For the speed measuring one incremental encoder may be used for both Collamat together. Notice also that the goods scanner GSC1 of the slave is connected in parallel to the GSC3 input of the master.

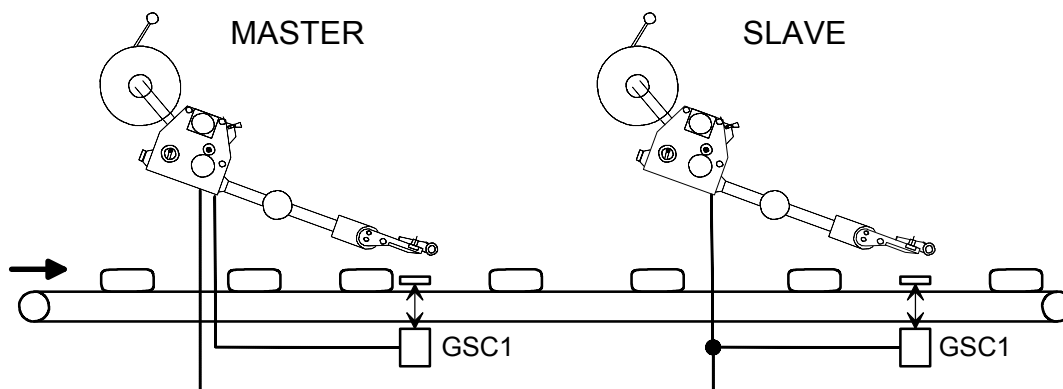

Figure 35: Placement of the two Collamat

### 10.0.1 Setting up of the Nonstopmode

When the wiring of the Nonstopmode is made, the installation must be set up as follows:

- Stop the conveyor or the goods transportation
- Remove all the goods in between of the two GSC1
- Switch both labelers off
- Set up the two labelers
- Choose Nonstopmode MASTER on the master
- Choose Nonstopmode SLAVE on the slave
- Switch both labelers on
- Start the conveyor or the goods transportation

The goods are now labeled in the Nonstopmode. If an error occurs which causes a stop of a Collamat the following proceeding is necessary:

- Service the erroneous condition on the stopped Collamat

If an error occurs which stops both Collamat, first the error condition must be serviced. Then the Nonstopmode must be set up again, as described before.

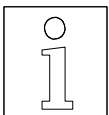

**Remark:**

**A position setting or a good suppression setting on the master will take place for both goodscanners (GSC1 and GSC3).**

**On the slave labeler the settings must be the same to prevent bad labeling results.**

**The mechanical distance between the dispensing edge and the product scanner must be the same on both labelers.**

## 11 Testmode

The firmware of the Collamat 6600 has a standard test-, diagnostic- and programming routine. This routines are called when the DIL-switch TEST is set to on at power on.

In the testmode, the motor is started and stopped periodically with the speed, set on the SPEED potentiometer. If there are any labels threaded through the Collamat 6600, the labels will be dispensed periodically. The DATA-HOLD switch is supervised. Dependent to its position, the potentiometer values are scanned or stored.

In the testmode, the Collamat 6600 can be controlled by an ASCII-terminal or a PC with a terminal emulation software. The communication with the Collamat will be done through the connector X104 using the RS232 protocol. The test software is menu driven an self explaining. The user language is English.

To communicate with a PC a serial communication cable is used. The figure 36 shows the electrical connections of the serial cable:

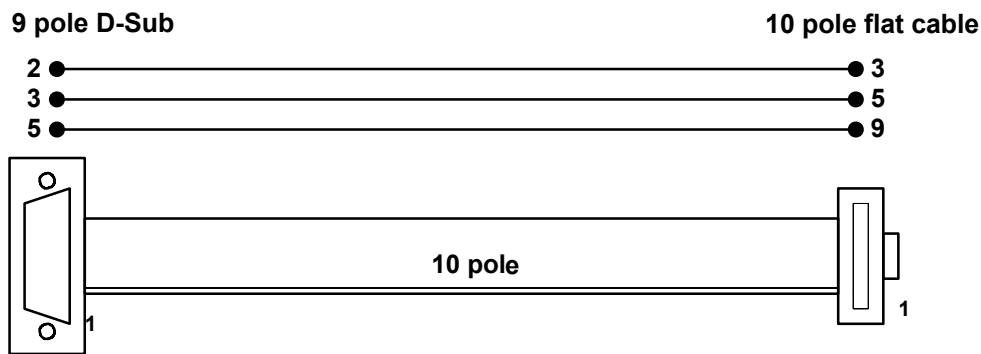

Figure 36

Communication parameters	Terminal settings
9600 Baud, 8 Bit, 1 Stop Bit, No Parity	TTY, Text

Figure 37 shows how to connect the Collamat 6600 to a PC:

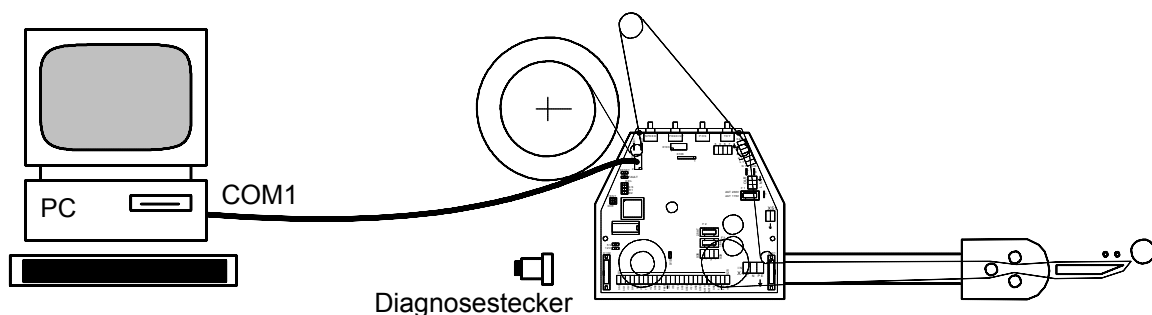

Figure 37: Test connections

## 11.1 Testprogram

When the Collamat 6600 is connected to the terminal, it must be switched on. At this moment the DIL-switch TEST must be set to on. The traction unit begins to turn with the speed set on the SPEED potentiometer. The terminal shows the following message:

```
COLLAMAT 6600 V1.011

Motor intervall test. Use spacebar to leave
```

Pressing the spacebar stops the motor intervall test. Now the following help menu will be displayed:

```
Helpmenue for C6600 Testprogram
-----
H  :  Help
M  :  Motortest
N  :  Motor intervall test
B  :  BUS-signal selftest
S  :  Signals display
D  :  DIL-switch settings
O  :  Potentiometer parameters
P  :  Potentiometer settings
I  :  Incrementalencoder
E  :  EEPROM Data
V  :  Version and Serial-No

Select Testfunctions with the Keys H,M,N,B,S,D,O,P,I,E,V
>
```

The testfunctions can be called with the appropriate keys. All testfunctions can be stopped with the spacebar.

### 11.1.1 Motortest

The Motortest is used for measuring the phase currents of the motor. The motor turns with the speed set on the SPEED potentiometer.

```
>m
Motortest. Use spacebar to leave
```

### 11.1.2 Motor intervall test

The **Motor intervall test** tests the labelling functions of the Collamat 6600. If a label web is threaded through the dispenser, labels will be dispensed periodically with the speed set on the SPEED potentiometer.

```
>n
Motor intervall test. Use spacebar to leave
```

### 11.1.3 BUS-signal selftest

The **BUS-signal selftest** tests all in- and outputs of the Collamat signalbus. For this test a diagnostic connector (see figure 35) must be plugged into the busconnector X102 (left side).



**Attention:**

To avoid damage of peripheral units or sensors, all sensors and bus-cables must be removed from the connectors.

```
>b
BUS-signal selftest
Testing FEED+LSC.....OK
Testing FEED+READY....OK
Testing TCY+GSC1.....OK
Testing NSTPO+GSC2....OK
Testing CLK+NSTPI.....OK
ERROR and IFEED signals blink until spacebar is pressed
```

This test will display faulty signalpairs on the terminal screen. If the test is started without the diagnostic connector the following message is displayed:

```
>b
BUS-signal selftest
Testing FEED+LSC.....not OK !
Testing FEED+READY....not OK !
Testing TCY+GSC1.....not OK !
Testing NSTPO+GSC2....not OK !
Testing CLK+NSTPI.....not OK !
ERROR and IFEED signals blink until spacebar is pressed
```

Figure 38 shows the schematic diagram of the diagnostic connector:

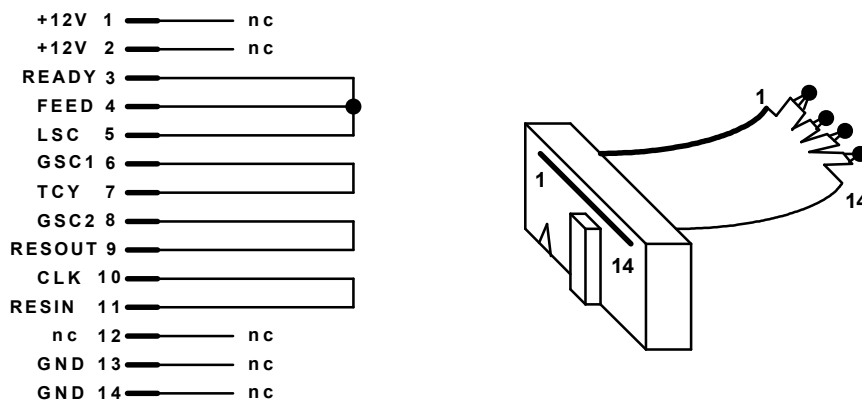

Figure 38: Diagnostic connector

### 11.1.4 Signal display

This test displays the levels of the input signals. It is used to test the function of the sensors and input circuits.

```
>s
Signals display. Use spacebar to leave
GSC1  GSC2  GSC3  READY  LSC  NSTPI  FAULT
OFF   OFF   OFF   OFF   OFF  OFF   OFF
```

### 11.1.5 DIL-switch settings

This test shows the position of the DIL-switches. It is used to test the function of the DIL-switches.

```
>d
DIL-switch settings. Use spacebar to leave
TEST  DIR  DEL  NS  R1  R2  HOLD
ON    OFF OFF OFF OFF OFF OFF
```

### 11.1.6 Potentiometer settings

This test shows the position of the potentiometers. It is used to test the function of the potentiometers.

```
>p
Potentiometer settings. Use spacebar to leave
SPEED  PRE.  POS.  TCY
1023   0255  0071  0641
```

### 11.1.7 EEPROM Data

This test checks the EEPROM and displays its data. (The data are volatile !)

```

>e
EEPROM Data
Test EEPROM : Ok !
Addr:  0000  0001  0002  0003  0004  0005  0006  0007
Data:  0631  0057  0287  0119  1E03  6501  6400  0078

Addr:  0008  0009  000A  000B  000C  000D  000E  000F
Data:  FFFF  FFFF  FFFF  FFFF  FFFF  FFFF  0007  AAAA

```

### 11.1.8 Version and Serial-No

This test shows the firmware version, the release date and the serial number of the controller print.

```

>v
Version and Serial-No.

COLLAMAT 6600
Version   : V1.011
Date     : 25. Juni 1996
Serial No.: 0007

```

## 11.2 Potentiometer parameters

On the Collamat 6600 the potentiometers can be programmed. With this function the working range of the potentiometers can be matched to a special labelling condition. To enable the potentiometer programmability, the DIL-switch TEST must be set to ON.

The following table shows the standard potentiometer range with its upper and lower values.

Potentiometer	Standardvalue			Parameter		Range	
	min.	max.	Range	min.	max.	min.	max.
<b>SPEED</b>	3 m/min	30 m/min	27 m/min	3 m/min	30 m/min	3 m/min	27 m/min
<b>PREDISP.</b>	0 mm	100 mm	100 mm	0 mm	250 mm	25 mm	250 mm
<b>POSITION</b>	0 mm	100 mm	100 mm	0 mm	250 mm	25 mm	250 mm

The function is called by pressing the **O** key. Then the Collamat 6600 gives the following message:

```
>o
Potentiometer parameters.
S      : Speed          03   30 m/min
P      : Predispensing 000 100 mm
O      : Position       000 100 mm
R      : Reset to factory settings
SPACE : Exit
Select function with the Keys S,P,O,R,SPACE
```

The potentiometers can be selected with the **S**, **P** and **O** keys respectively. The **R** key resets all values back to the factory settings.

For example the **SPEED** potentiometer will be programmed to a lower speed of 10 m/min and an upper speed of 20 m/min.

```
>s
SPEED (m/min)

U      : Upper limit
L      : Lower limit
ENTER : Keep
SPACE : Exit
Select limit with the keys U,L,ENTER, SPACE
```

With the **U** key the upper value is selected. **L** selects the lower value.

```
>u
Alter value: + or -, Keep: ENTER, SPACE: Exit
SPEED Upper limit : 20
```

Using the **+** and **-** keys the value may be increased or decreased. When the desired value is displayed, the dataentry may be finished with the **ENTER** key.

```
U      : Upper limit
L      : Lower limit
ENTER : Keep
SPACE : Exit
Select limit with the keys U,L,ENTER, SPACE
>
```

The lower value will be selected with the **L** key and adjusted with the **+** or **-** keys. When both values match the desired range the dataentry will be finished with the **ENTER** key.

Now the entered values are displayed and a request to store it in the EEPROM is asked.

```
SPEED limits
Upper limit : 20
Lower limit : 10
Store data ? Y/N
```

Pressing the Y key stores the data. This function will be skipped with the N key. If the data are stored the following message will be displayed:

```
Updating EEPROM.....OK
>
```

After this message the parameter menu will be displayed again. Now choose an other potentiometer with its appropriate key or quit the function with the SPACE key.

### 11.3 Incremental encoder programming

The function **Incremental encoder** helps programming the speed measuring with an incremental encoder. The first invocation of this function displays the following screen:

```
>i
Incremental-Encoder setting is OFF
Distance between two pulses is: 100/100 mm
+      : ON
-      : OFF
M      : Modify
R      : Reset to factory settings
ENTER : Keep
SPACE : Exit
Select function with the keys +,-,M,R,ENTER,SPACE
```

The + or - keys are used to switch the speed measuring with an incremental encoder on or off. After pressing the **M** key the step width of the encoder can be entered. The **R** key resets all values to the factory settings. The **ENTER** key stores all data into the EEPROM.

In the following example (see also page 40) the incremental encoder is programmed to a step width of 1.57 mm:

```
>m
Enter new distance (1/100 mm) : 157
```

The value is entered in 1/100 mm without period and terminated with the ENTER key.

After pressing the ENTER key the following message will be displayed:

```
New distance is : 157/100 mm
+       : On
-       : Off
M       : Modify
R       : Reset to factory settings
ENTER  : Keep
SPACE  : Exit
Select function with the keys +,-,M,R,ENTER,SPACE
```

Now the incremental encoder can be turned on by pressing the + key.

```
Incremental-Encoder ON
```

The **ENTER** key now stores all datas into the EEPROM. This procedure must be confirmed with the **Y** key:

```
Incremental-Encoder setting is ON
Distance between two pulses is: 157/100 mm
Store Data ? Y/N
```

After pressing the **Y** key the programming of the incremental encoder is finished.

```
Updating EEPROM.....OK
```

To reset the programming of the incremental encoder to the factory settings the **R** key must be pressed. The following message then is displayed:

```
>r
Incremental-Encoder setting is OFF
Distance between two pulses is: 100/100 mm
Store Data ? Y/N
Updating EEPROM.....OK
```

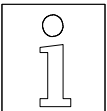

**Remark:**

To use the speed measuring with an incremental encoder, the DIL-switch R must be switched to ON, the encoder also must be programmed to ON, and the programmed width must match the mechanical step width.

## 12 Incremental encoder

The electrical connection of an incremental encoder is described in the chapter **Connection of the goods scanners**. The programming is described in the chapter **Testmode**. Now the mechanical attachment of the conveyor to the encoder will be described.

If the speed measuring is done by an incremental encoder, the measured speed can be fine adjusted by  $\pm 10\%$  with the SPEED potentiometer. The DATA HOLD switch only stores the potentiometer setting. The dispensing speed will follow the product speed.

Figure 38 shows an example how to calculate the step width:

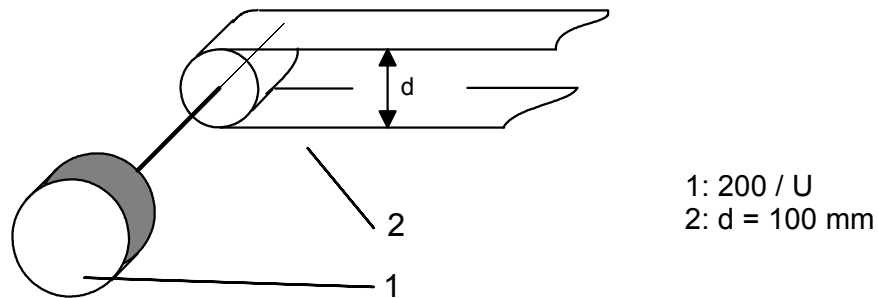

Figure 38: Incremental encoder

Example:

$$\text{Step} = \frac{d * \text{Pi}}{\text{Pulse}} = \frac{314\text{mm}}{200} = 1.57\text{mm}$$

The step width must be in between 1.00 mm and 9.99 mm. For small distances between the products, the stepping rate must be as small as possible. 2 mm are a good practice value.

The minimum dispensing speed is 3 m/min, the maximum speed is 30 m/min. If no incremental encoder is attached to the dispenser or if the conveyor is stopped, the dispensing speed will be 3m/min.

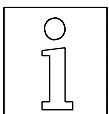

**Remark:**

**The minimum distance between two products is equal to 6 times the step width.**

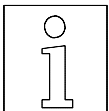

**Remark:**

**The dispensing speed is captured at the moment of the detection of the product. At this moment the dispensing speed will not change until the label is completely dispensed !**

### 13 Control of a hotstamp with the IFEED signal

Two different type of hotstamps (NPN or PNP) can be connected. Figure 39 shows how to connect different hotstamps. Figure 40 shows the timing diagram.

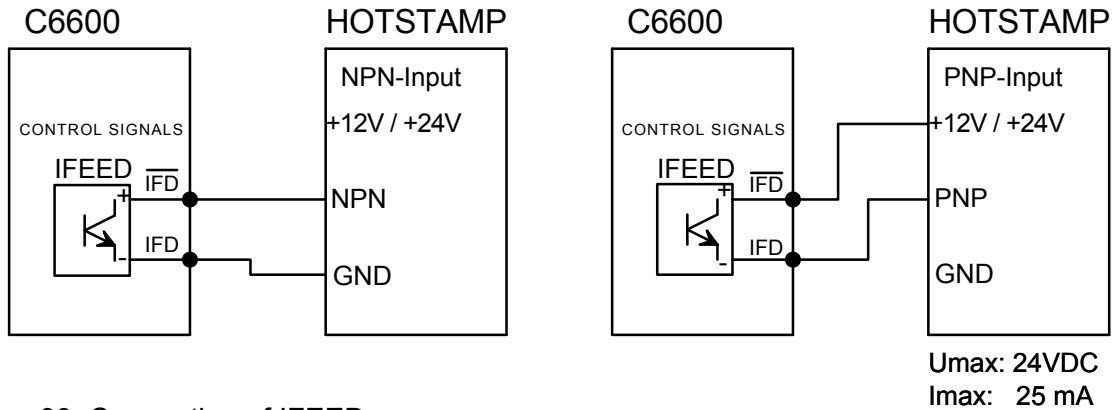

Figure 39: Connection of IFEED

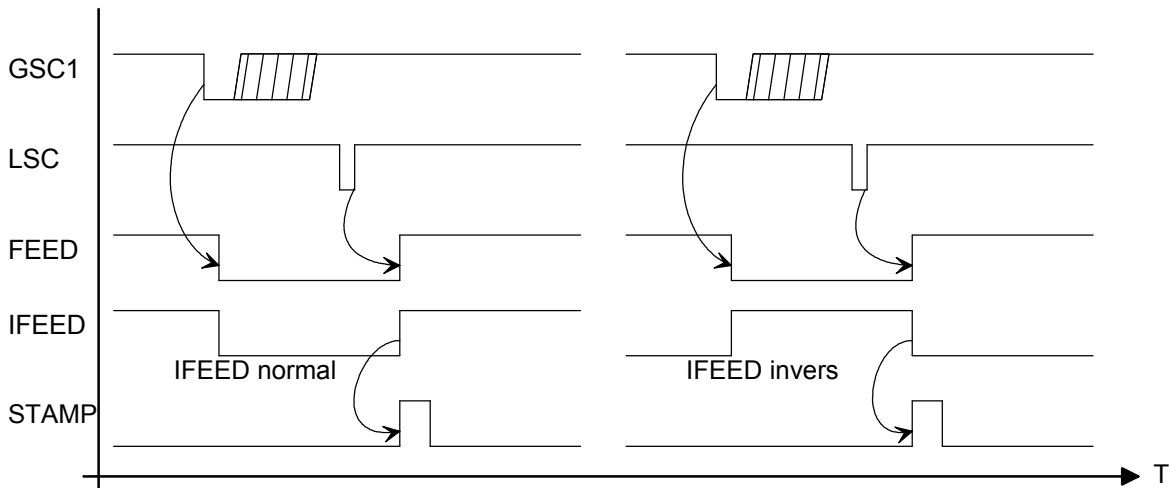

Figure 40: Timing diagram

Dependent to the manufacturer and the model, the polarity of the triggering signal of the hotstamp must be changed. This adjustment is to be set with the jumper X105 on the dispenser board, to **normal** or **inverse**. The position of the jumper X105 can be found on figure 11.

## 14 Cabling and setting up

For a trouble free operation of the Collamat 6600 following items must be observed:

- Trained personnel
- Ambient temperature
- Absence of dirt and dust
- Absence of splashing water
- Installation and setting up of the installation
- Installation and setting up of the Collamat 6600
- Electromagnetic interferences
- Safety regulations and safety requirements

### 14.1 Cabling

Electromagnetic interferences can lead to non repeatable and not obvious errors while labelling. Most times misplaced layout of the cabling, RMI and ESD interferences disturb the labelling. Because of this, the following rules must be observed for the cabling:

- Separated mains and signal cables
- Use shielded cables
- All units must be grounded
- Connect only devices which meet the RMI standards
- Use power filters in interfered environments and interfered mains supplies

### 14.2 Setting up

The setting up must be done carefully by trained personnel. The following items must be observed:

- Visual check of the labeler unit
  - Are all electrical and mechanical units correctly attached ?
  - Are all connectors accessible ?
- Connect the labeler to the mains and switch it on
  - Is the power switch illuminated ?
- Turn off the labeler and unplug it
- Set up the DIL-switches according to the desired mode. Motor turning direction.
- Attach the goods scanner signals to the labeler
- Connect the remaining units to the labeler
- Connect the labeler to the mains and switch it on
  - Do the peripheral units work OK ?
- Thread the paperweb and adjust the label scanner
- Dispense a label. Is it dispensed correctly ?

## 15 Version numbers

Dispenser board	
Part number	Version
5215.7500A	Basic version from first series
5215.7500B	Fuse F2 changed to 3.15AT
5215.7500C	Second revised version

Firmware		
Version	Date	Characteristics/Modifications
1.01	01.15.1996	Basic version from first series
1.011	25.06.1996	Improved startup in Testmode

## 16 Glossary and terms

### 16.1 Short cuts

<b>ESD</b>	<b>E</b> lectro <b>S</b> tatic <b>D</b> ischarge
<b>RMI</b>	<b>R</b> adio <b>M</b> agnetic <b>I</b> nterference
<b>GND</b>	<b>G</b> rou <b>N</b> D
<b>IR</b>	<b>I</b> nfra <b>R</b> ed
<b>LED</b>	<b>L</b> ight <b>E</b> mitting <b>D</b> iode
<b>nc</b>	not connected
<b>RS232</b>	Standard serial data exchange protocol

### 16.2 Signals

<b>ERROR</b>	Errrorsignal caused by any error of the Collamat
<b>FEED</b>	Signal indicating the labelling process
<b>GND</b>	<b>G</b> rou <b>N</b> D
<b>GSC</b>	<b>G</b> oods <b>S</b> Canner
<b>IFEED</b>	Isolated <b>FEED</b> signal
<b>LSC</b>	<b>L</b> abel <b>S</b> Canner
<b>nc</b>	not connected
<b>NSTPI</b>	<b>N</b> on <b>ST</b> o <b>P</b> <b>I</b> N-put
<b>NSTPO</b>	<b>N</b> on <b>ST</b> o <b>P</b> <b>O</b> U <b>T</b> -put
<b>READY</b>	<b>RE</b> ADY signal from peripheral units
<b>TCY</b>	<b>T</b> ransparen <b>CY</b> , control current for the label scanner IR-diodes

## 16.3 Terms

**Stopping accuracy:** Accuracy of the paper transportation

**Unwinder:** Device that carries the full paperweb rolls and unwinds it

**Adapter:** Part of the labeler by which the label is peeled off from the paperweb and applied onto the products

**Rewinder:** Device that takes the empty paperweb from the traction unit and rewinds it

**CE-Mark:** Certification for the European market, means: Conformité Européenne

**Collamat:** Brand name for a labeler built by HM Collamat AG

**GSC:** Goods SCanner

**Flap adapter with magnet:** Adapter which moves down to the product during the labelling

**LSC:** Label SCanner

**Position:** Sticking position of a label on the good

**Predispensing:** Predispensing of a label on the peeling plate

**Motorstep:** Travelling way of the label for one motorstep

**Dispensing speed:** The speed of the goods to which the labels are stucked

**Startfrequency:** Highest possible frequency for a stepper motor to start moving without loss of steps

**Traction Unit:** Part of the dispenser with drive unit and electronic control

## 17 Technical data

### Dispenser general data (standard values)

System	Units	C6610	C6620
Version		right/left	
Dispensing speed	m/min	3.0-30	
Min. label width	mm	10	
Max. width of the paperweb	mm	95	160
Min. label length	mm	10	
Min. label length at max. dispensing speed	mm	20	
Stop accuracy	mm	± 1 mm at 30 m/min	
Minimal gap for optical scanner	mm	2	
Minimal gap for mechanical scanner	mm	2	
Max. diameter of paperroll	mm	250/350	
Max. weight of paperroll	kg	10	
Noise figure	dBA	< 70	

### Traction unit

System	C6600	
Driver	2 phase stepper motor, 200 steps	
Motor voltage	70V	
Max. phase current	4.0 A	
Type of protection	IP40	
Ambient temperature	+5-40 °C	
Ambient humidity	15-90%, non condensing	
Noise figure max.	< 70 dBA, 1 m distance	
System	C6610	C6620
Weight	12 kg	14 kg

## Midi-unwinder

Diameter of the roll core	42 mm
Max. outside diameter of roll	350 mm
Max. weight of roll	10 kg
Spring dancer with automatic brake	

## Flap adapter

System	C6610	C6620
Max. width of paperweb	95 mm	160 mm
Weight	1.9 kg	2.2 kg
Version	right/left	
Adapter angle	±90°, with adjustable snap-in locking	
Recuperating spring force	adjustable	
Additional press time of adapter	adjustable	
Max. turning angle	15°	
Ambient temperature	+5-40°C	
Ambient humidity	15-90% non condensing	

## Label scanner

Optical label scanner
Mechanical label scanner

**The informations in this handbook reflect the state  
of the publication date.  
We reserve the right to make design modifications.**

## 17.1 Dimensions - systemdesign

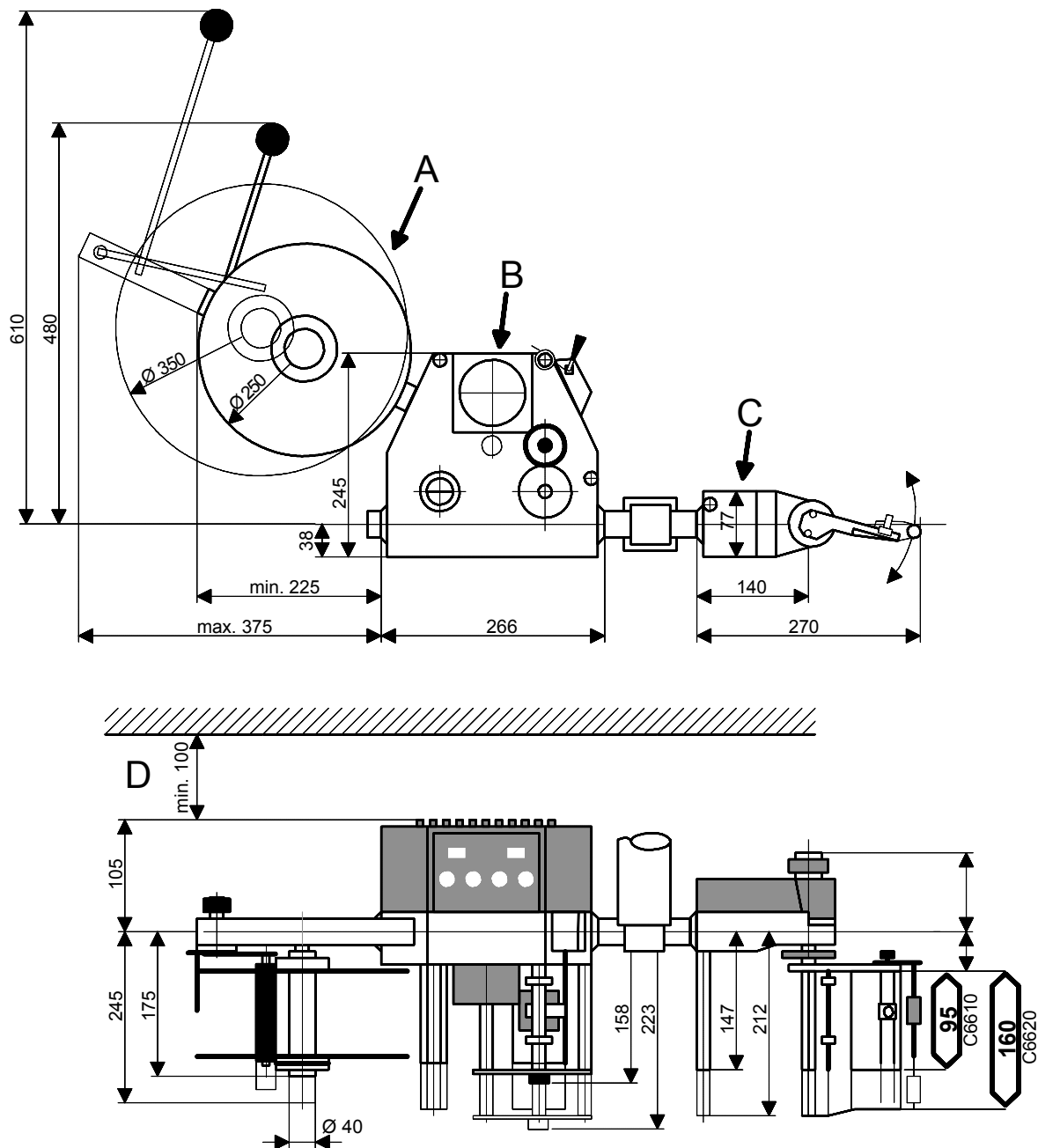

A) Abwickler  
B) Vorzugwerk  
C) Klappenadapter  
D) Für Deckelmontage

A) Unwinder  
B) Traction unit  
C) Flap adapter  
D) For lid dismantling

## 18 Troubleshooting

### 18.1 Troubleshooting Collamat 6600

The troubleshooting will proceed along the paperpath. See following figure:

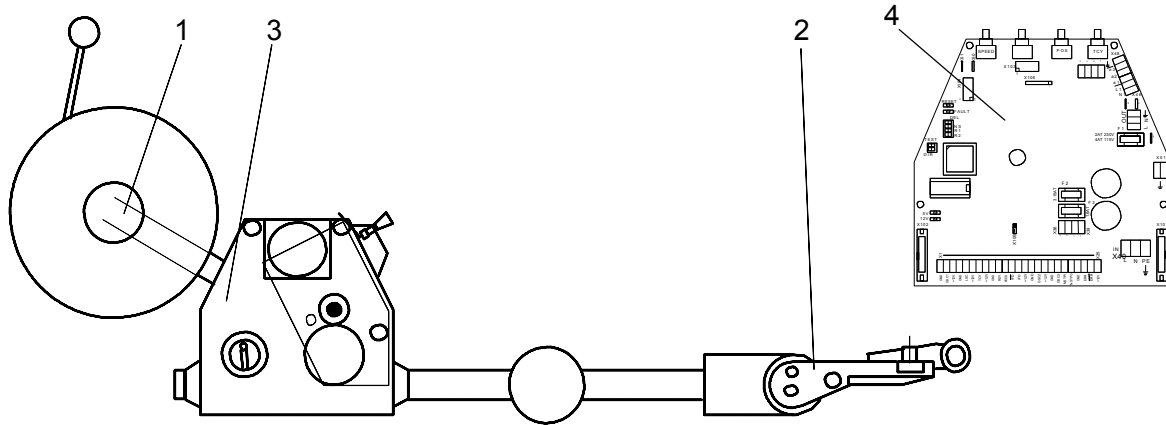

#### Unit

1. Unwinder      2. Adapter      3. Traction unit      4. Control print

1. Unwinder troubleshooting		
SYMPTOM	DIAGNOSIS	ACTION
Labels peel off at the dancer roll	Dancer roll diameter is too small	Change the standard roll against a roll with enlarged diameter
Dancer arm is bent and breaks	Dancer arm material is too weak or too thin (older Collamat)	Use new dancer arms (C3600/C6600/C8600)
Flange of the fixed disk breaks	Material defect, wrong type of aluminum	Replace flange against new series flange
Unwinder blocks	Disk touches the diskbrake	Shift the disk on the unwinder shaft away from the diskbrake
	Shaft is blocked	Lubricate the bearings on the shaft
	Diskbrake does not open	Readjust the diskbrake
The torsion spring comes off the knurled knob	Wrong kind of torsion spring	Exchange the torsion spring against an according torsion spring
The unwinder tends to fall off while side labeling	Paper roll too heavy	Mount a separate clamp to the module rail to stiffen the unwinder rail
Dancer roll gets shaky	Shaft screw is loose	Fix the screw (use perhaps Loctite)
Dancer bearing gets shaky	Module rail is worn out by the dancer axle	Replace module rail and dancer axle

<b>1. Unwinder troubleshooting</b>		
<b>SYMPTOM</b>	<b>DIAGNOSIS</b>	<b>ACTION</b>
Paperweb falls off in side labeling applications	Missing side labeling kit	Mount the side labeling kit to the Collamat

<b>2. Adapter troubleshooting</b>		
<b>SYMPTOM</b>	<b>DIAGNOSIS</b>	<b>ACTION</b>
Labels run through	Roll-up cable is broken	Replace roll-up cable
	Label sensor cable is broken	Replace label sensor cable
	IR transmitter cable is broken	Replace transmitter cable
	IR transmitter LED broken	Replace transmitter print
	Label sticks below the label sensor	Remove the sensor and clean it properly
	IR light guide is blind	Replace IR light guide
	TCY-potentiometer is misadjusted	Readjust TCY, check DATA-HOLD-switch
	Label scanner position not over the label	Place the scanner over the label transport path
Pressing roll is worn out	Roll is pressed too hard to the goods	Lift the labeler, reduce the adapter spring force
Pressing roll axle hangs/is bent down	Fixing hex nut is loose	Retighten the hex nut (apply Locktite)
	Pressing roll axle is bent or broken	replace the axle
Adapter flap gets shaky	Lever fixing screw is loose	Remove the flange holding the two knurled rolls and retighten the lever
Labels are not dispensed straight forward	Peeling bar is worn out	Replace the peeling bar
Labels form bubbles	Labeling speed too fast	Reduce labeling speed
Labels form wrinkles	Labeling speed too slow	Increase labeling speed
	Labeler is misaligned to product transport	Realign the labeler
Adapter tilts down while labeling	Backing paper not threaded between the adapter roll pair	Tread the paperweb correctly between the adapter roll pair

<b>2. Adapter troubleshooting</b>		
<b>SYMPTOM</b>	<b>DIAGNOSIS</b>	<b>ACTION</b>
Paperweb breaks behind the peeling bar	Lateral paperguides hurt the paperweb	Enlarge the space between the paperguides
	Paperbrake set too hard	Reduce the braking force
	Peeling bar is too sharp	Use peeling bar with a bigger radius
		Add Teflon tape around the peeling bar
	Peeling bar touches the goods	Lift the labeler/adapter away from the goods
Paperweb is perforated	Use unperforated paperwebs or use a peeling bar with bigger radius	

<b>3. Traction unit troubleshooting</b>		
<b>SYMPTOM</b>	<b>DIAGNOSIS</b>	<b>ACTION</b>
Pressure roller is shaky	Pressure roller shaft is broken	Replace pressure roller shaft
Traction roller turns in the wrong direction	Problems in the rewinder clutch	Release the breaking force of the rewinder
	Feltdisks are worn out	Replace the felt disks
	Parallel pin inside the rewinder shaft is blocked	Release the parallel pin clean and lubricate it
Potentiometer settings have no effect	DATA-HOLD-switch active	Switch it off
Motor is very hot	No fault	This is normal for a stepper motor
Motor makes high frequent noise	No fault	This is normal for a stepper motor
Traction roller is shaky while power on	Pin at the front flange of the traction roller is broken or worn out	Exchange pin or if necessary exchange the complete traction roller
	The toothed belt roll or the locking plate is broken	Exchange the toothed belt roll or exchange the locking plate and fix it tight
At higher labeling speed the motor stalls	Too much friction of the paperweb	Check the paperbrake
		Add Teflon tape to the peeling bar
		Reduce all friction of the paperweb where possible
At higher labeling speed the motor stalls	Too much friction of the paperweb	Check the unwinder dancer
	Clutching force of the rewinder is too high	Release the breaking force of the rewinder or replace the felt disks

<b>3. Traction unit troubleshooting</b>		
<b>SYMPTOM</b>	<b>DIAGNOSIS</b>	<b>ACTION</b>
Paperweb breaks behind the paperbrake	Lateral paperguides hurt the paperweb	Enlarge the space between the paperguides
	Paperbrake set too hard	Reduce the braking force

<b>4. Control print troubleshooting</b>		
<b>SYMPTOM</b>	<b>DIAGNOSIS</b>	<b>ACTION</b>
Motor is dead, power switch is not illuminated	No mains connected to trafo	Check for correct main connection
		Check main fuse
		Check internal main switch wiring
Motor is dead, power switch is illuminated, FAULT-LED is on	Motordriver probably not working	Check motordriver fuse F2
		Check for undervoltage
		Check for motordriver overheat
		Check on motorwires for short connection
		Check trafo wiring
Motor turning direction is wrong	Wrong DIL-switch DIR setting	Change DIL-switch DIR
	Wrong Motor wiring	Reconnect motor wires according to the Technical Handbook
Collamat labels only at 3m/min	Labeler is set to incremental encoder	Change DIL-switch R2 to OFF
Motor makes noise and shakes. It does not turn correctly	Faulty motor driver chip	Replace the board
	Missing connection of one motor wire	Connect motor wires according to the Technical Handbook
No action after power on but motor is under power	Probably set to Nonstop slave mode	Switch Nonstop mode to off
The potentiometers are broken	Transportation damage	Use the original transport box
The primary fuse often blows	The mains impedance is too low	Use an extended power cord
The 5V and 12V LEDs are both off	Fuse F3 is blown, probably result of a short of the 12V in the peripheral units	Check the peripheral units, replace the fuse (1.6AT)
The 12V LED is off	Probably result of a short of the 12V in the peripheral units	Check the peripheral units
The 5V LED is off	Probably result of a short of the 5V in the processor part	Replace the board
The RESET LED is on	Undervoltage of the 5V circuit	Replace the board

**4. Control print troubleshooting**

SYMPTOM	DIAGNOSIS	ACTION
The RESET LED periodically flashes	Microprocessor error	Replace the board
	EPROM faulty	Replace the EPROM

## 18.2 Trouble shooting checklist

<b>Machine-Type:</b>		Ser. No. Dispenser board:	Ser. No. Labeler:
<b>Environment</b>	Mains voltage:	Frequency Hz:	Temperature °C:
	Humidity %:	Interference level (Burst):	Interference level ESD (Static):
<b>Labels</b>	Width:	Length:	Gap:
	Thickness:	Transparency:	Material:
<b>Paperweb</b>	Width:	Thickness:	Transparency:
<b>Goods</b>	Kind:	Material:	Shape:
	Length:	Width:	Height:
	Speed m/min:	Length in sense of transport:	Distance between goods:
<b>Labeler</b>	Speed m/min:	Pieces / min.:	Measuring:
<b>Settings</b>	Predispensing:	Position mm:	Suppression:
	TCY value:	Label length:	Suppression:
<b>Special:</b>			
<b>Machine- environment</b>	Conveyor:	Feeder:	Taker:
	Other machines around:		
<b>Peripheral units</b>	1	2	3
<b>Screening</b>	Mains cables:	Sensor cables:	
<b>ESD-Phenomena</b>	Description:		
<b>Description of the mal-functions:</b>	Accumulation:		
Date / ev. date and time of the last disturbances:			
<b>Comments</b>			
Disturbance registered by Name: Date:			

Please make a copy of this list before using it.