

HM Collamat AG
Pfeffingerring 201
CH-4147 Aesch
Switzerland

Phone +41 61 756 28 28
Fax +41 61 756 29 29
contact@collamat.ch
www.collamat.ch

Collamat 8600

Technical handbook

Index	page
1 Safety advices	5
1.1 Important warnings	5
1.2 Danger indications	5
1.3 Symbol descriptions	6
2 Introduction	7
2.1 General informations	7
2.2 The Monitor	7
2.3 The Firmware	8
2.4 The Dispenser	8
3 The Collamat 8600 Labeller	9
3.1 Prevention of accidents	9
3.2 Noise suppression	9
3.3 Mechanical stability	9
4 Assemblies	10
5 Mechanical adjustments	11
5.1 Traction unit	11
5.1.1 Threading the label web	11
5.1.2 Adjustment of rewinder coupling force	11
5.1.3 Readjustment of paper brake	12
5.1.4 Longitudinal adjustment on the module rail	12
5.2 Flap adapter	13
5.2.1 Inclination adjustment of flap adapter	13
5.2.2 Adjustment of the pressure roller of the flap adapter	13
5.2.3 Adjustment of the optival label scanner	14
5.2.4 Adjustment of the mechanical label scanner	15
6 The Monitor C8600	16
6.1 Construction	16
6.2 The control panel	17
6.3 Construction	18
6.4 Hardware	18
6.4.1 Firmware memory IC6, EPROM 128 Kbytes	19
6.4.2 The LCD-Display	19
6.4.3 Adjusting the contrast	19
6.4.4 Exchanging a defective LCD	19
6.5 The backpanel	20
6.6 The mains filter board	21
6.6.1 Exchange of the mains filter board	21
6.7 The Interfaceboard	22

Index	page
6.7.1 The power supply	22
6.7.2 Fuses	23
6.7.3 Exchange of the interfaceboard	24
6.7.4 Terminals and connectors	24
6.7.5 Particulars	24
6.8 The motor driver	25
6.8.1 Settings	25
6.8.2 Status indicators	25
6.8.3 Exchange of the motordriver	26
6.9 Traction unit C8600	26
6.10 Control signals for external units	27
6.10.1 FEED	27
6.10.2 READY	27
7 Signals and connector pin assignments	28
7.1 Inputs	28
7.1.1 Photocoupler inputs	28
7.1.2 Comparator inputs	29
7.2 Functional description of the inputs	29
7.2.1 Goods scanner GSC1 and GSC2 (Good SCanner)	29
7.2.2 Goods scanner GSC3	30
7.2.3 Control input NSTPI (NonSToP In)	30
7.2.4 Control input STOP	30
7.2.5 LSC (Label SCanner)	31
7.2.6 TUNIT (Traction UNIT)	31
7.2.7 READY	31
7.2.8 LLO (Label LOw)	31
7.3 Outputs	31
7.3.1 Isolated outputs	31
7.3.2 Open-Collector outputs	32
7.4 Functional description of the outputs	33
7.4.1 Mode indicator RUN	33
7.4.2 Warning signal NOK (Not OK)	33
7.4.3 Error signal ERROR	33
7.4.4 Connection of a signalisation to the monitor	33
7.4.5 Signal FEED, IFEED	34
7.4.6 Stepermotor clock CLOCK	34
7.4.7 Control output NSTPO (NonSToP Out)	34
7.5 Connector layouts of the monitor C8600	35

Index	page
7.5.1 Connector X3, DISPENSER	35
7.5.2 Connector X7, CONTROL SIGNALS	36
7.6 Connector layouts traction unit C8600	37
7.6.1 Connector X101, X102 BUS	37
7.7 Connection diagram	38
7.8 How to connect a goods scanner	39
7.9 Goods scanners	40
7.9.1 Speed measuring CS IR goods scanner	40
7.9.2 NPN Reflexscanner, Lightbeam scanner	40
7.10 Optical label scanner	40
7.11 Signalcable connection	41
7.12 Adapter with magnet	42
7.13 Flatprinter board	43
8 Nonstop labelling	44
8.1 Proceeding	44
8.2 Setting up of the Nonstop mode	45
9 Speed measuring	46
9.1 Incremental encoder	46
9.2 Measuring goods scanner	47
10 Motor and motorcable	48
10.1 Motorcable	48
10.2 Connection of the motorcable	48
11 Control of external devices	49
11.1 Control of a Hotstamp with the IFEED signal	49
12 Monitortest with a diagnostic connector	50
13 Cabling and setting up	50
13.1 Cabling	51
13.2 Setting up	51
14 Password	52
14.1 By keyboard	52
14.2 By keyswitch	52
15 Fuses	53
16 Glossary	53
16.1 Short cuts	53
16.2 Signals	53
16.3 Terms	54
17 Technical data	55
17.1 Dimensions - systemdesign	58

Index	page
18 Troubleshooting	60
18.1 Troubleshooting Collamat 8600	60
18.2 Trouble shooting checklist	65

1 Safety advices

1.1 Important warnings



Before installing and operating the Collamat 8600 read following safety instructions.

- The Collamat 8600 labeler is exclusively determined for labelling goods. It must exclusively be controlled and driven by a monitor C8600.
- The installation of a Collamat 8600 has to be done by a trained specialist. For this you have to consider the national specific regulations of
 - prevention of accidents
 - mechanical stability
 - construction of electrical and mechanical systems
 - noise suppression
- Take notice to the technical data of the Collamat 8600. Especially the environment conditions must be observed.
- The operation of the Collamat 8600 must be done by trained personnel.
- In case of non-authorized modification, guarantee will fall.
- Before connecting non-standard products, ask your competent technical supporter.

1.2 Danger indications

- The safety symbols and danger advices on the Collamat 8600 and in this manual must strictly be observed.
- Before connecting or disconnecting the labeler to or from the monitor C8600 the monitor must be switched off.
- The monitor and the distribution box may only be opened by authorized personnel.
- Before opening the distribution box, the monitor must be separated from the mains power.
- It exists danger of pinching hair, jewelry, ties, clothes etc. into the traction unit.
- It exists danger of injury by cutting fingers in the area of the paper web.
- It exists danger of injury in the area of the dancers of the rewinder and unwinder of the Collamat 8600.
- It exists danger of injury in the area of the paper stockcontroller of the Collamat 8600.
- To operate on the Collamat 8600 the operating personnel must keep to a safely place to prevent injury by the products being labeled.

1.3 Symbol descriptions



ATTENTION

Indicates danger of damaging the Collamat 8600 or other system components, with a potential consequential danger of injuries.

DANGER

Indicates an immediate hazard for persons.

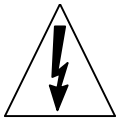

DANGER

Shock hazard due to high voltage at component.



DANGER

Hazard due to high temperature component.



ATTENTION

ESD warning (Electro Static Discharge). The PC boards or component may only be touched in an electrostatically protected environment.

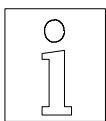

NOTE

Important or additional information to Collamat 8600 or to the documentation.

2 Introduction

2.1 General informations

This technical handbook describes the construction and the function of the Collamat 8600. In addition to the operating instructions, it contains the necessary tips and adjustments to get optimum use of the Collamat 8600. The descriptions of each electrical or mechanical device also helps for quick error analysis and error elimination.

We recommend you to replace the complete electronic boards. Return it to HM Collamat AG or to its representative for repair. You can then feel sure, that the high quality standard of the Collamat 8600 can also be guaranteed after a repair.

Special characteristics of the Collamat 8600:

- resistant to wear, no clutch/brake-system
- robust, stable
- easy installation and operation due to the modular construction
- simple to operate due to the menu operated software
- quick change-over to other labelling tasks
- high performance
- high reliability
- latest SMD-technology
- high precision 3-phase stepper motor

2.2 The Monitor

The power supply and the controller electronics are built into a stable metallic case. All peripheral modules are connected to a connector box which is connected to the backpanel of the monitor by one single D-sub-connector. A well dimensioned heatsink allows the operating of the monitor without additional fans. The monitor may be mounted in various positions.

The monitor contains following parts:

- **Noisefilter with voltage selector**
The noisefilter keeps RMI outside, so it may not interfere with the controller electronics. It also prevents outgoing RMI to the mains supply. The voltage selector allows versatile adaptation of the powersupply to different mains voltages.
- **Transformer**
This component gives the energy for all the components of the Collamat 8600
- **Interfaceboard**
The interfaceboard connects the motordriver to the power supply and to the controller. It contains also all the electronics of the power supply. The interfaceboard shapes all the input- and outputsignals to and from the controller.

- **Motordriver**
The 3-phase motordriver is a standard component of a leading motor and motordriver manufacturer. The driver gives the power to the stepper motor. The step-rate may be adjusted from 200 up to 1000 steps per revolution. Standard in the Collamat 8600 are 500 steps per revolution.
- **Controllerboard**
It is built up with a Hitachi H8/532 microcontroller, EPROM with firmware, LC-Display and flat-panel keyboard. The controllerboard controls all the labelling sequences, the LC-Display, the keyboard and the nonvolatile memory.
The LC-Display has four lines with 20 characters each and a backlight illumination. The controllerboard is the frontpanel and the controller in one part.

2.3 The Firmware

The firmware of the Collamat 8600 has following features:

- Modern human interface
- 6 digits preselect and goods counter
- Adjustable suppression of the label scanner signal in relation to the label length to detect transparent or preprinted labels
- Adjustable signal suppression of the goods scanner in relation to the goods speed and length after labelling
- Programmable adjustment of the labelling position on the goods
- Programmable adjustment of the predisensing
- Multiple labelling functions with adjustable distance of the gap between the labels
- Automatic capture of the labelling speed by measuring the transportation speed of the goods with speed measuring photocells or incremental encoder
- 20 program memories
- Protection of the memories by password access
- Two user levels
Supervision of the labelstock and out of label, end of paperweb, not closed pinchroller in the traction unit, motordriver OK-signal
- Nonstop mode with two Collamat 8600 systems
- Multilingual user display
- Automatic label scanner adjustment
- Full operation of all to labelling important parameters while labelling
- Full control to all peripheral assemblies by keyboard - no potentiometers and switches necessary

2.4 The Dispenser

The traction unit as well as the other peripheral units are mounted on a modular rail. All surfaces of the units are treated against water and they are corrosion resistant. The coating of the traction unit is specially treated to avoid slippage on the paperweb while labelling. The force of the paperbrake is adjustable. The tractionroller turns free while power off for easy threading and installation of the paperweb.

3 The Collamat 8600 Labeller

The installation of the Collamat 8600 must be done by a trained personnel. For this you have to consider the national specific regulations of

- prevention of accidents
- noise suppression
- mechanical stability
- construction of electrical and mechanical systems

3.1 Prevention of accidents

While installing and connecting the monitor and the dispenser C8600 together keep care that the signalcables and powercables can't become obstacles. The cables must be placed and installed according to the national safety requirements. Keep care that the signalcables are not placed beneath powercables.

3.2 Noise suppression

The dispenser and monitor C8600 are shielded according to the CE directives. Only cables that are certificated by HM Collamat AG may be used for connecting the monitor with the dispenser and the mains power. Additional peripheral assemblies must be connected to the auxiliary mains outlet of the monitor. These assemblies must be certificated by HM Collamat AG.

3.3 Mechanical stability

If the Collamat 8600 is used on a movable stand, this stand must be capable to be tilt 10° in each direction. See also following figure 1:

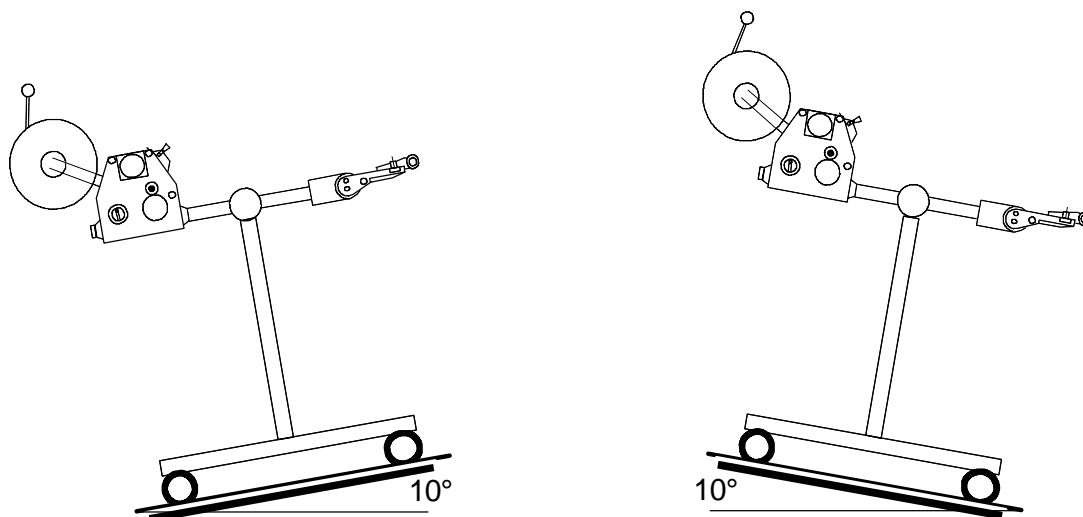

Figure 1: Stability of the stand

4 Assemblies

In the following description the assemblies of the Collamat, their adjustment and maintenance are described. First an overall view of the dispenser.

The assembly parts are mounted and placed on a modular rail. Following figure 2 shows these assembly parts with their names on the modular rail:

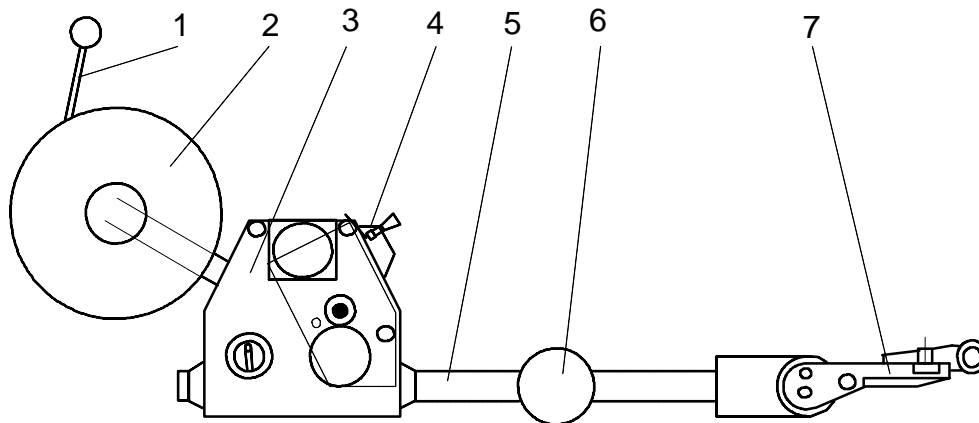

Figure 2: Assembly parts

Legend of the assemblies

- | | |
|--------------------|-----------------------------------|
| 1. Unwinder dancer | 5. Modular rail |
| 2. Unwinder | 6. Support |
| 3. Traction unit | 7. Adapter (optional with magnet) |
| 4. Paper brake | |

5 Mechanical adjustments

5.1 Traction unit

5.1.1 Threading the label web

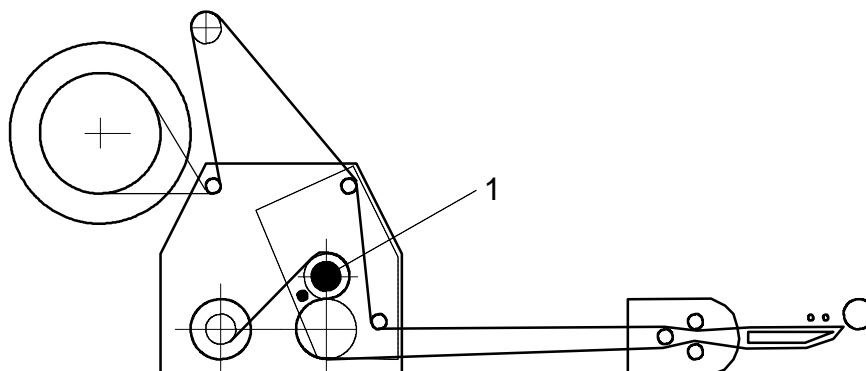

Figure 3

Thread the label web as shown in figure 3 up to the dispensing edge and draw it out by approx. 1 m. Detach the labels from the paperweb at the drawn-out web. Then open the pinchroller by turning the knob 1, place the paperweb over the dispensing edge and finish threading the paperweb as shown in figure 3. Close the pinchroller. Adjust the side guides of the paperweb well, leaving 0.5 mm free space to the paperweb's edge.

5.1.2 Adjustment of rewinder coupling force

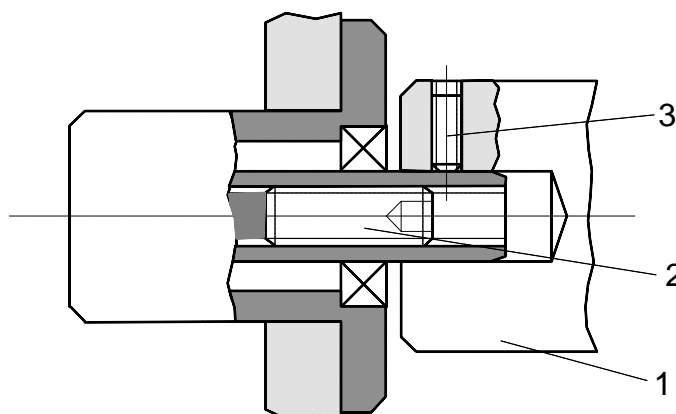

Figure 4

The coupling force of the rewinder is factory-set. Proceed as follows if out of adjustment: Detach winding spindle 1 after unscrewing the M5-bolt 3. Screw M8-bolt 2 accordingly:

- in= harder coupling
- out= softer coupling

5.1.3 Readjustment of paper brake

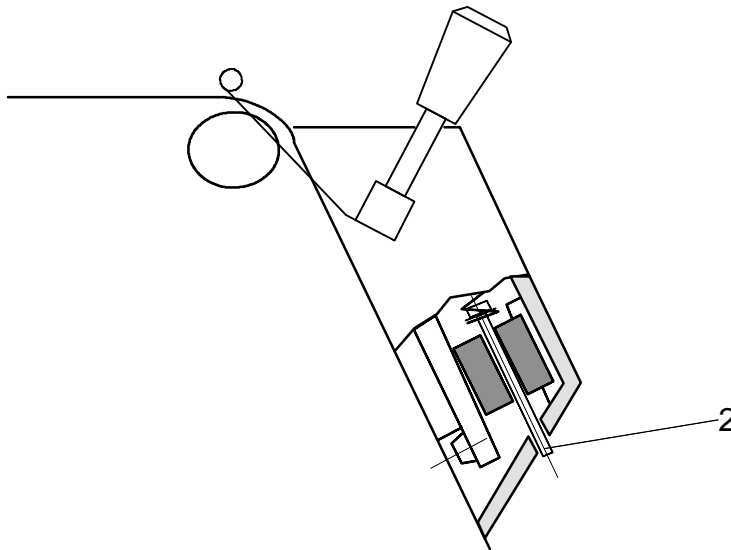

Figure 5

The braking force is factory-set to an optimum value. Should it, however, be unadjusted, readjust it with the M3-bolt 2 in the web-end controlbox of the traction unit, from the outside.

- Screw in bolt = higher braking force
- Unscrew bolt = lower braking force

5.1.4 Longitudinal adjustment on the module rail

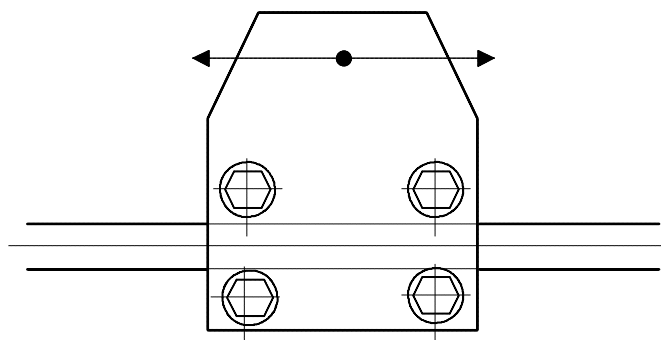

Figure 6

Unscrew 4 bolts with special tool (wrench for socket head cap screws 5 mm) one half turn (adapter only 2 bolts).

Move device, observing scale on module rail. Then tighten bolts equally.

5.2 Flap adapter

5.2.1 Inclination adjustment of flap adapter

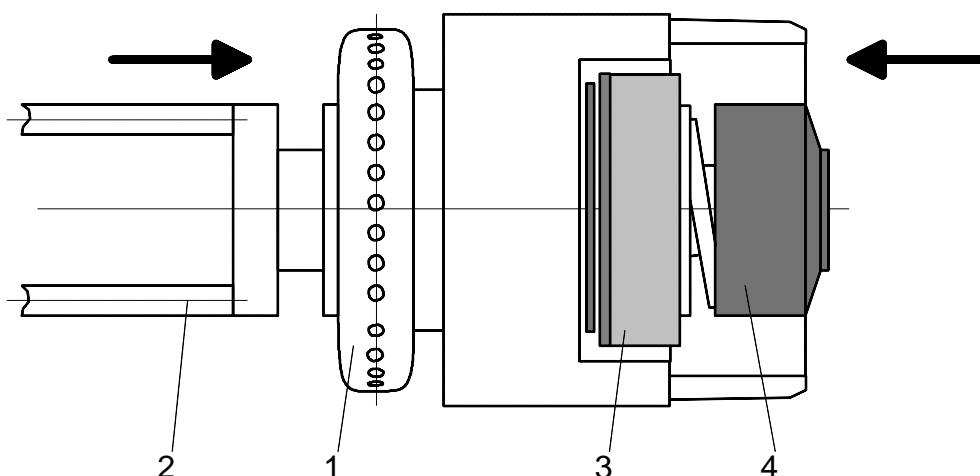

Figure 7

The inclination of the flap adapter can be changed against the module rail: Unscrew nut **1** with two turns (refer to figure 7), with special hexagonal spanner (included as accessory). Push adapter in the direction indicated by the arrow **2**, turn to desired setting at ring **3**. Retighten nut **1**. The pressure force of the flap adapter without magnet or of the magnetic flap adapter is variable: push in button **4** in the direction indicated by the arrow, twist for appropriate spring tension and adjust until it meets the next stop.

5.2.2 Adjustment of the pressure roller of the flap adapter

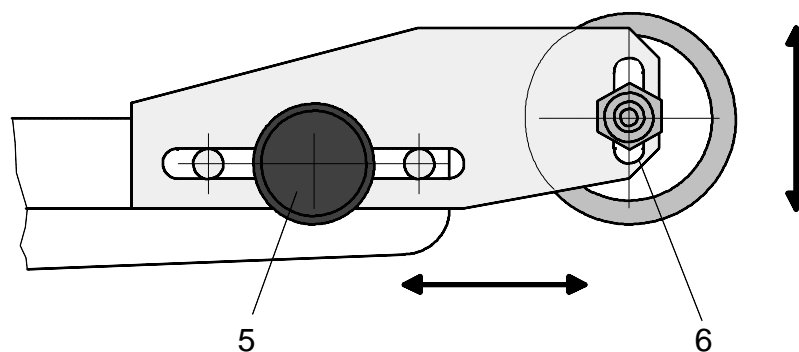

Figure 8

The pressure roller of the adapter can be adjusted depending on the labels and goods:

- Horizontal adjustment with the knurled nut **5**
- Vertical adjustment with the hexagonal nut **6**

5.2.3 Adjustment of the optical label scanner

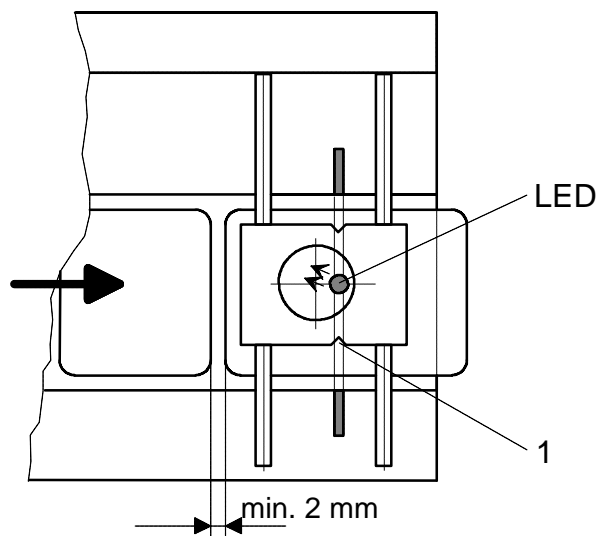

Figure 9

Proceeding of the adjustment of the optical label scanner:

Pull the labelweb so that the gap is located below the marking **1** of the scanner. Switch on the Collamat 8600 monitor. Set the label scanner in the menu Labels scanner sens. -> Auto adjust by pressing the ENTER key. The monitor now automatically sets the scanner to the transparency of the backing paper.

If the auto adjust did not get a correct value the scanner can be adjusted manually. For this procedure pull the labelweb so that the gap is located below the marking **1** of the scanner. Now increase the scanner value from zero on manually until the red LED on the scanner goes off. Continue pulling the labelweb until a label is located below the scanner. Now continue increasing the scanner value until the LED switches off again.

The best setting now is at the middle value of the two settings with turned the LED off.

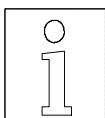

Remark:

If the setting of the optical label scanner is faulty, the gap between the labels will not be detected. After triggering a labelling operation, the labeler will not stop until the length which is set with Label length is moved. An error message will then be displayed.

For transparent labels, please use the mechanical label scanner.

5.2.4 Adjustment of the mechanical label scanner

The mechanical label scanner (not used on magnetic flap adapter) is an alternative to the optical label scanner and is mainly used for transparent labels.

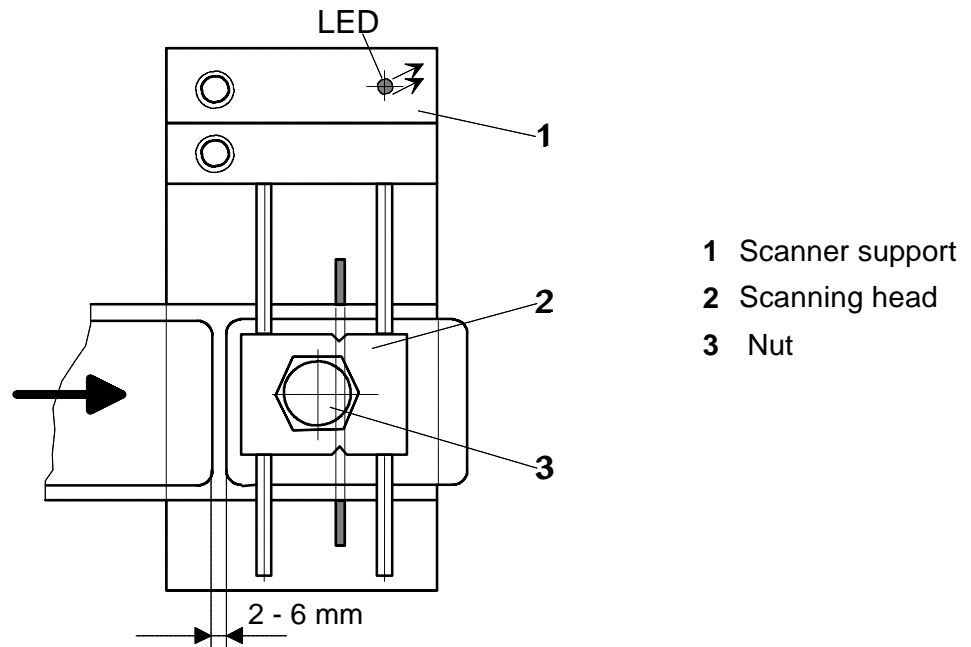
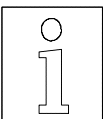

Figure 10

Adjustment:

- Place the label under the scanning head, the LED on the scanner support must be turned on. If this is not the case, unscrew the nut on the scanning head and turn it counterclockwise until the LED turns on.
- Turn the scanning head clockwise until the LED turns off.
- Turn the scanner one quarter turn forward and retight the nut.
- Place the gap between the labels under scanning head, the LED-display must be turned on.



Note:
No adjustment is necessary on the Monitor!

6 The Monitor C8600



The monitor must be unplugged from the mains supply before it is opened. Inside of the monitor charged capacitors can lead to shock hazard. Wait at least 10 seconds before opening the monitor.

6.1 Construction

All the controller electronics for the Collamat 8600 labeler are built in to a stable steel cabinet. This cabinet contains no adjustable controls inside. All settings can be done by keyboard. After removing the two screws from the backpanel the cover can be separated from the heatsink.

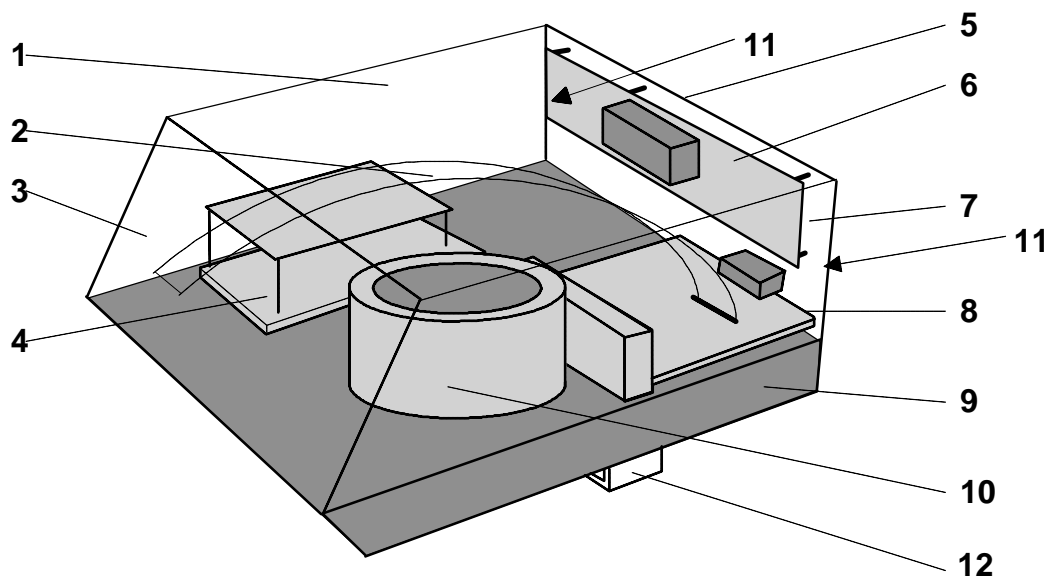

Figure 11: Monitor

Legend

- | | |
|-----------------------|--------------------|
| 1. Cover | 7. Mains switch |
| 2. Flatcable | 8. Interfaceboard |
| 3. Control panel | 9. Heatsink |
| 4. Motordriver | 10. Transformer |
| 5. Backpanel | 11. Locker screws |
| 6. Mains filter board | 12. Mounting clamp |

The cover 1 carries the control panel 3 and protects the parts inside the monitor. It can be removed after unlocking the screws 11 and slightly shifting the cover to the front side of the heatsink 9.



ATTENTION:
The cover must be removed carefully. Otherwise the flatcable 2 or its connectors can be damaged.



ATTENTION:
The electronic components of the control panel must not be touched without ESD safety precautions. The controller is sensitive to electrostatic discharge.

6.2 The control panel

The control panel of the monitor C8600 is a standalone unit that contains a microprocessor. It is at the same time frontpanel and the control- or administration processor. All settings and adjustments of the Collamat 8600 are programmed and handled in this unit. The settings and adjustments are stored in the control panel even if the power is turned off.

It is possible to install the monitor in two different positions. Due to this the frontpanel can be installed in two ways. (See figure 12). Therefore the panel is hold with six fixing bolts to the cover. It can be removed or assembled by clicking it out or in from or onto the cover. Take care to the flat-cable. It must not be wrenched or squeezed.

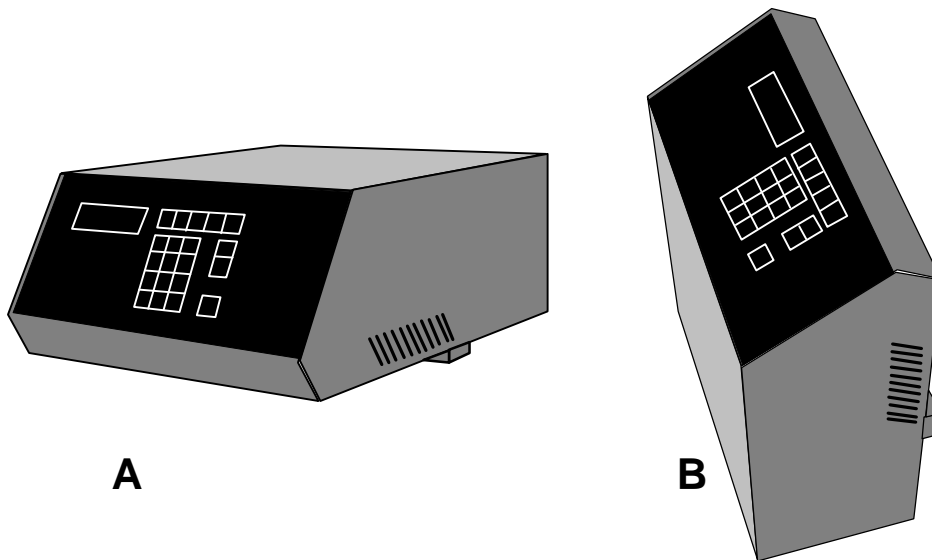

Figure 12: Installation modes

When the frontpanel is removed from the cover, keep care that the fixing bolts are not damaged. After reassembling the frontpanel with the cover, open the fixing bolts a bit with a little screwdriver or a tool that fits the little slots of the bolts by hand without taking too much force. The frontpanel must fit tight to the cover.



ATTENTION:
While assembling or disassembling the frontpanel, the copperside or the frontside can be damaged. You must not use sharp tools like knives or screwdrivers.

Keep care to the ESD safety precautions.

6.3 Construction



The control panel contains ESD sensitive components. Take precautions against ESD while working with the control panel.

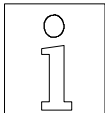

If a control panel is defective, it must be exchanged. Any repairs not made by HM Collamat AG will expire the guarantee.

The control panel builds together with the frontpanel one unit. This unit is connected with one 50 pole flatcable to the interfaceboard. The flatcable leads all signals to the interfaceboard and the power supply to the control board. All electronic components are soldered in SMD technology onto the board.

The frontpanel contains the keyboard. This keyboard is equipped with switchcontacts under the front foil. The contacts have a clicking function. This helps to feel the function of the keys. So it is easier to operate in a noisy environment.

The LCD-display is, like the LED's for the operationmode display, covered behind the front foil.

Figure 13 shows the rear view of the controlboard. All SMD components, the LCD-display and the flatcable connector are placed here.

6.4 Hardware

The circuit is built around a microcontroller H8/532. This controller serves the LCD-display, the keyboard and the control signals to the motordriver and to the labeler. All in- and outputs of the board are protected against electromagnetic interference's (RMI) with filters. This secures a safe operation and prevents the board from radiate RMI. Figure 12 shows the components on the component side of the control board.

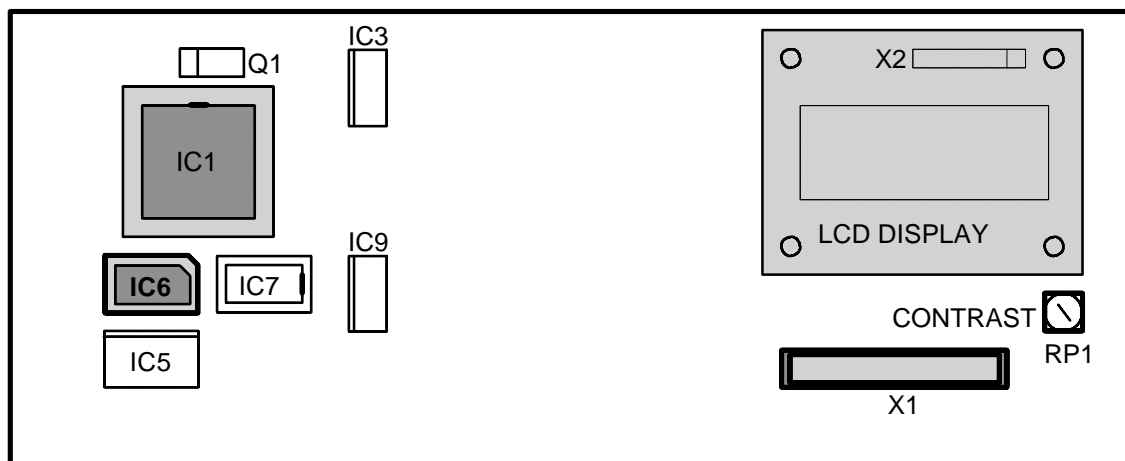

Figure 13: Rear view of the control board

6.4.1 Firmware memory IC6, EPROM 128 Kbytes

The firmware is programmed into a 27C010-type EPROM. This EPROM has a PLCC-package. For exchanging the EPROM you need a special PLCC extracting tool. The position of the EPROM is shown in figure 13.

While inserting the EPROM, keep care that the diagonal edge of the package fits the diagonal side of the socket. Press the EPROM into the socket by a slight pressing with your finger until you feel it snaps in.

The program memory IC6 is programmed with the firmware of the two Collamat 8600 and 9100. The firmware makes out the connected interfaceboard by a specific code of the board.



If the EPROM is extracted with the wrong tool, the socket may be damaged.

6.4.2 The LCD-Display

The LCD-display has four lines with 20 character types. It shows all the user information and the labeler conditions. The backlight illumination can be turned on and off by the microcontroller. The illumination gives a good reading of the informations of the display in dark environment.

6.4.3 Adjusting the contrast

For this adjustment the little trimmer RP1 on the component side is used. (See also figure 12). This trimmer must be operated with a special screwdriver for SMD components. If you use another kind of tool, the trimmer can be damaged. Never apply force to the trimmer !

6.4.4 Exchanging a defective LCD

First all four fixing screws of the LCD must be removed. Then all the 16 solder points of the connector X2 must be unsoldered from the soldertin. The new LCD is now inserted over the 16 contact pins and fixed with the four fixing screws. Before you resolder all the pins, watch the parallelism of the LCD to the front foil.



Before you change the LCD, watch the guarantee regulations. For broken LCD's no guarantee is given! Unauthorized soldering on assemblies while guarantee time, lapses the guarantee.

6.5 The backpanel

On the backpanel the mains connectors and the connectors for the labeler can be found. The mains connectors are connected to the mains filter board. This board contains the mains connector, the mains switch, the mains filter and outlet and an additional noisefilter for the motordriver.

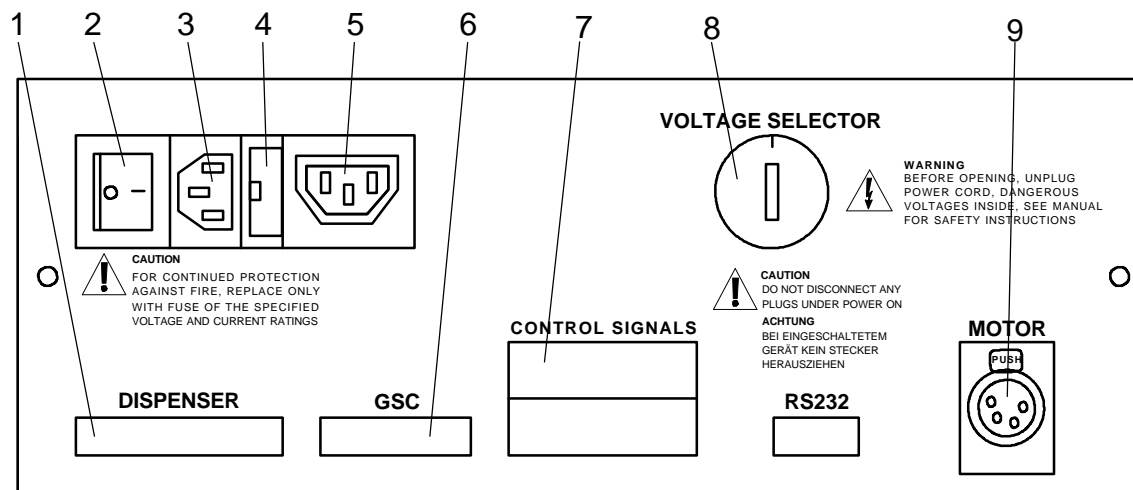

Figure 14: Backpanel Monitor C8600

Legend

- | | | |
|----------------------|-----------------|----------------------------|
| 1. Labeler connector | 4. Fuse holder | 7. Signal relays connector |
| 2. Mains switch | 5. Mains socket | 8. Voltage selector |
| 3. Mains plug | 6. Blind cover | 9. Motor connector |

Only units approved by Collamat Stralforsare allowed to be connected to the mains socket **5**. The following table shows the fuse current ratings and the maximum permissible current for the mains socket:

Mains-voltage (VAC)	Mains-fuse	Peak-current	Monitor-fuse	Max. load current
110/120 VAC	20 AT	30 A, 20 ms	10 AT	2 A
220/230/240 VAC	10 AT	30 A, 20 ms	5 AT	1 A

The monitor must be the first unit which is switched on in a heavy loaded mains. Otherwise the in-rush current may blow the mains fuse.



The signal relay contacts 7 only may be used to signalize operation conditions of the Collamat. These contacts must not be used to switch self-powered or dangerous units.

6.6 The mains filter board

The mains filter board is used to give a clean filtered mains voltage to the transformer. The board is mounted onto the backpanel and contains components on both sides.

The mains filter board carries a high efficiency mains filter, the voltage selector, the mains connectors, the mains sockets for the transformer and the mains fuses. The mains filter board also carries the RMI-filters for the motordriver. Figure 14 shows the mains filter board.



DANGER:

Before opening the monitor the mains connector must be unplugged. The mains filter board leads mains voltage! Danger of shock hazard due to high voltage at components.

Solder side

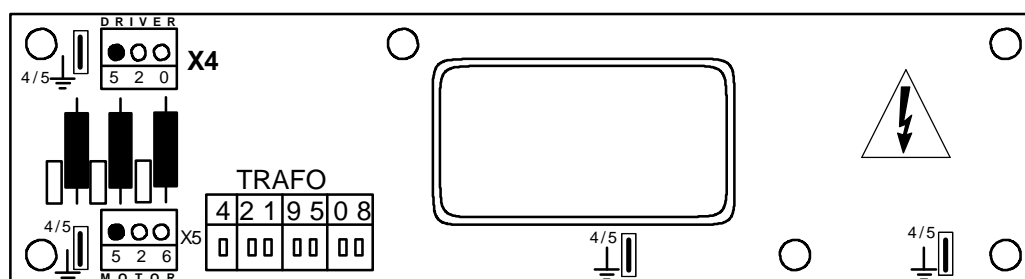

- 1: brn/bn
- 2: red/rt
- 3: org/og
- 4: yel/gb
- 5: grn/gn
- 6: blu/bu
- 7: vio/vi
- 8: gry/gu
- 9: wht/ws
- 0: blk/sw

Component side

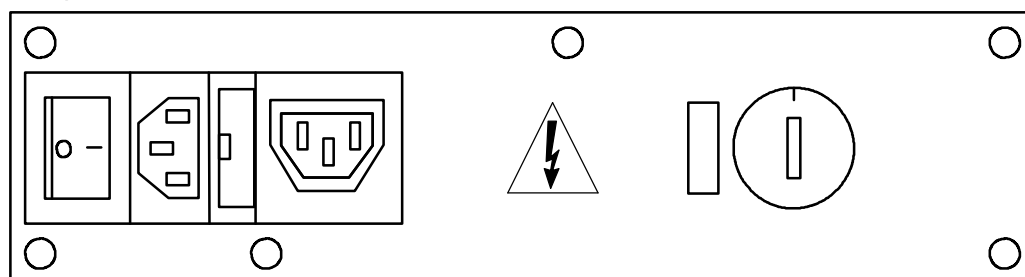

Figure 14: Mains filter board

6.6.1 Exchange of the mains filter board

To exchange the mains filter board all the cables leading to the board must be disconnected. Then the board may be removed after unscrewing all six screws. The new board is now first fixed with the six screws and then reconnected with the cables. Figure 15 shows the wiring of the mains filter board.



Attention:

After exchanging the mains filter board all the four grounding cables must be reconnected. If this is not carried out, shock hazard or malfunction of the monitor may happen.

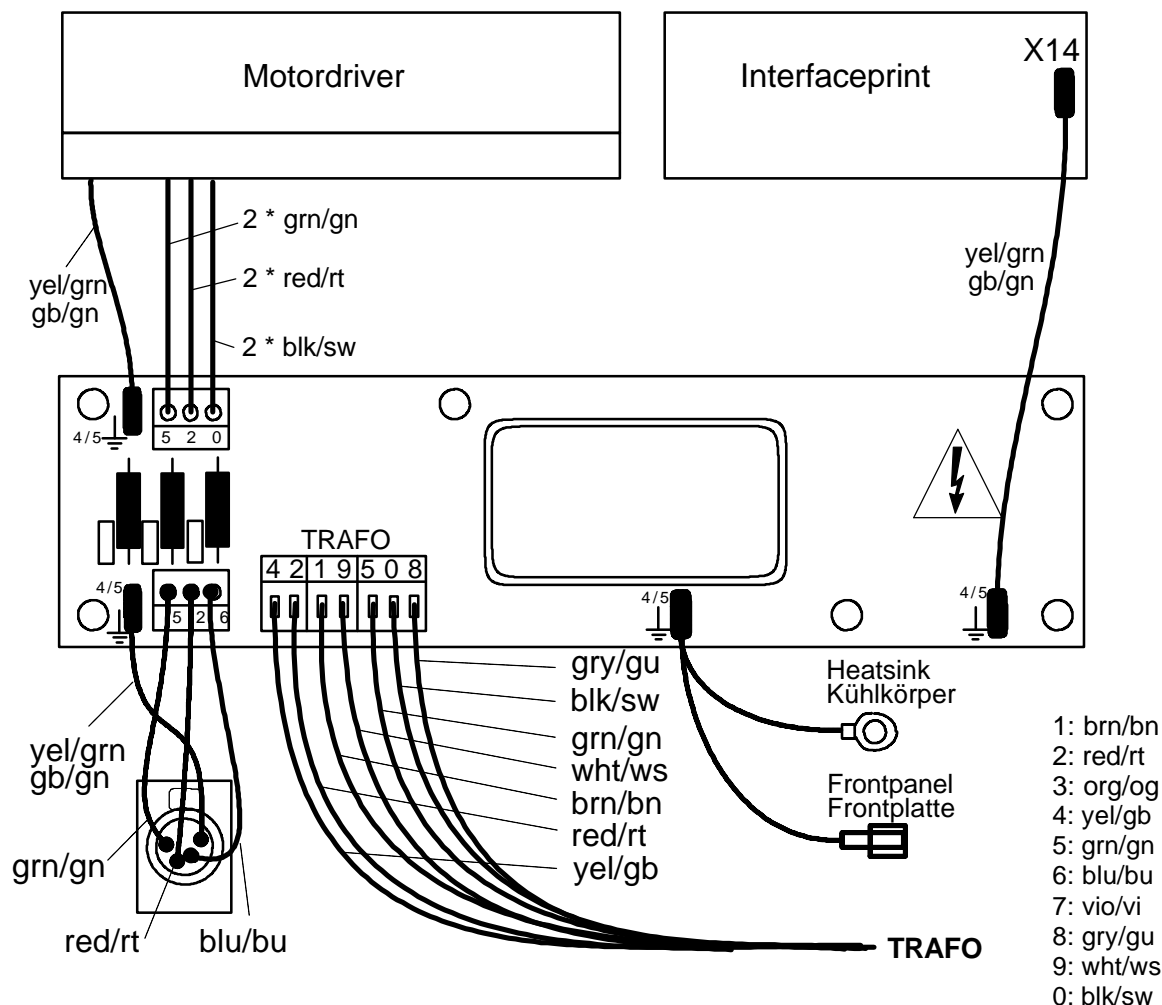

Figure 16: Wiring of the mains filter board



Attention:

After exchanging the mains filter board, the voltage selector must be set to the correct mains voltage to which the Collamat will be connected.

6.7 The Interfaceboard

The interfaceboard is used to connect the labeler and its peripheral units to the monitor. It filters and shapes all the signals of the labeler or of the installation to the logic level of the micro controller. The interfaceboard also contains the electronic parts of the power supply and feeds the motor-control signals to the motordriver. Figure 17 shows the position of the connectors of the interfaceboard.

6.7.1 The power supply

The transformer is connected to the terminals X11 and X12 of the interfaceboard. The voltage for the motordriver is connected to the terminal X11. Fuse F1 protects this voltage against overload. LED LD1 indicates the 120V for the motordriver.

The supply voltage for the logic and the sensors is connected to terminal X12. Fuse F2 protects this voltage against overload. LED **LD2** indicates **24V**. The voltage 12V and 5V are generated by the 24V using switching regulators. LED **LD3** indicates **12V**, LED **LD4** indicates **5V**.

The 5V and 12V supply's are protected against short connection and overload.

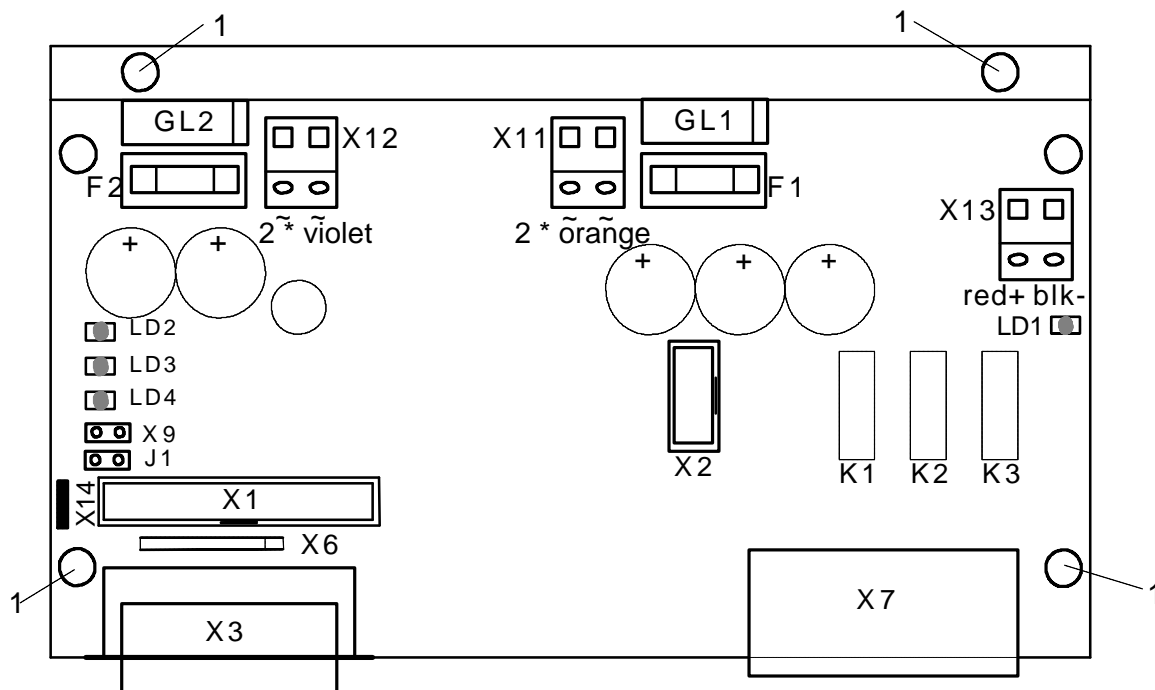

Figure 17: Interfaceboard

The following table shows the voltage and fuse values of the interfaceboard:

Voltage	Current	Fuse	Terminal ~	Terminal =	LED
120 V DC	2,2 A	F1 : 3.15A	X11	X13	LD1
24 V DC	1,5 A	F2 : 2,5 A	X12	-	LD2
12 V DC	500 mA	-	-	-	LD3
5 V DC	1 A	-	-	-	LD4

6.7.2 Fuses

If the voltage 120V or 24V is missing the corresponding LED is not lit. If the 24V lacks then the 12V and 5V also lack. Each voltage has its own LED. (See also above table). If a voltage is missing, the corresponding fuse must be checked. The fuses are located beneath the heatsink on the interfaceboard. If the fuse is blown first check what it caused. The fault must be rectified before the fuse is replaced.

6.7.3 Exchange of the interfaceboard

To exchange the interfaceboard, first all cables must be disconnected. After detaching the four fixing screws **1**, the board can be removed. Then the new board is inserted carefully and fixed with the four fixing screws **1**. When this is done the cables must be reconnected.

6.7.4 Terminals and connectors

The following table describes the terminals and connectors of the interfaceboard:

Terminal Connector	Description
X1	Flatcable connector to the frontpanel
X2	Motorclock and supervision signals of the motordriver
X3	DISPENSER-connector for the labeler
X6	Serial port for factory testing
X7	Signalrelais contacts
X9	Key switch
X11	Voltage supply from transformer, 85 VAC
X12	Voltage supply from transformer, 19 VAC
X13	Voltage supply to motordriver, 120 VDC
X14	Ground connector to the power filter board

6.7.5 Particulars



Attention:

While unplugging the flatcable from X1, keep care that the cable is pulled out carefully. It is easily damaged. Inserting the cable, watch for a correct position of the plug.

Connector X6 is used for testing the monitor at the manufacturer. For future time it will be possible to connect a PC or a modem to this connector.

Connector X7 gives isolated relais contacts. With these contacts external units like signal lamps or PLCs can be controlled. Also an isolated input allows to Start or Stop the Collamat by an external signal.

Connector **X9** is used to indicate the firmware there is a keyswitch attached. The keyswitch is then connected to **J1**. If the Key makes contact to J1 the user level is set to **Programmer**, otherwise it is Operator.

This connector X9 together with Jumper J1 also is useful when the password is lost. The password can then be cleared by entering **'0000'** in the password setting menu. See also chapter Password.

The ground connection X14 is used to connect the grounding wire to the mains p.c. board. If this grounding is not plugged in, malfunctions of the labeller may occur.

6.8 The motor driver

The motordriver board is an assembly which is developed and produced by a well-known manufacturer of steppermotors and steppermotordrivers.



The motordriver board is adjusted, tested and built into the monitor by HM Collamat AG. The settings must not be changed. The motor current must not be changed !

ATTENTION: No switch or jumper must be touched while power on !



DANGER

Disconnect all voltage supplies before working on the motordriver !

6.8.1 Settings

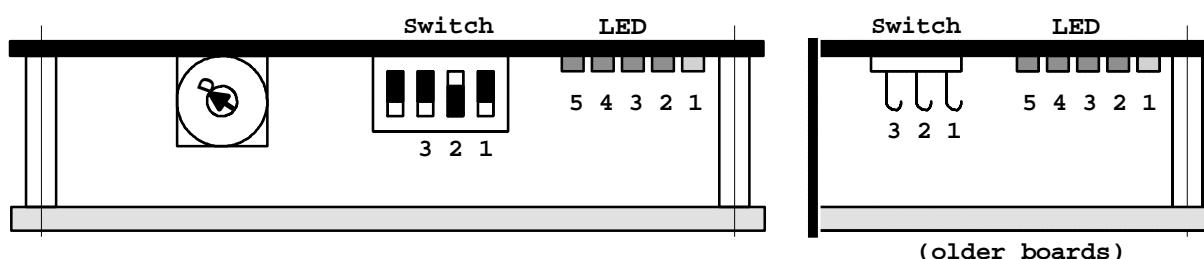

Figure 18: Motordriver settings

Set the hook switches S1, S2, S3 and the selector switch to the following positions:

S1 : open	S2 : closed	S3 : open	Selectorswitch : D
------------------	--------------------	------------------	---------------------------

6.8.2 Status indicators

The five LED's on the motordriver indicate operating states and any malfunction:

LED 1	lights up when the motordriver is operating properly. The supply voltage exceeds 80 VDC.
LED 2	lights up in case of a short-circuit between two motor phase leads.
LED 3	lights up in case of overtemperature ($> 75^{\circ}$) at the heatsink.
LED 4	lights up in case of overvoltage (>140 V) during operation with brake.
LED 5	lights up in case of undervoltage (< 80 V).

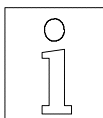

NOTE:

If a fault occurs (LED2 to LED5), the motor is deenergized and LED1 goes out. The fault condition is displayed on the monitor and can only be cleared by switching the monitor off and on.

6.8.3 Exchange of the motordriver

First the two plug clamps must be removed. Then the connector is unplugged and the motordriver can be detached from the heatsink by loosen the four screws placed on the heatsink. The new motordriver is now fixed with the four screws, connected to its cables and then secured by the plug clamps.

While assembling watch carefully that no dirt or dust is between the two heatsinks.

6.9 Traction unit C8600

The signals of the monitor C8600 are fed with one cable to the traction unit. All units are connected to the traction unit. Modules on the modular rail are connected with the buscable (14 pole flatcable). The following figure 19 shows the position of the connectors inside the traction unit. The colors of the wires are written on the board. This colors are only valid for peripheral units from HM Collamat AG. The connection cables of the sensors are fed to the inside of the traction unit with special clamps.

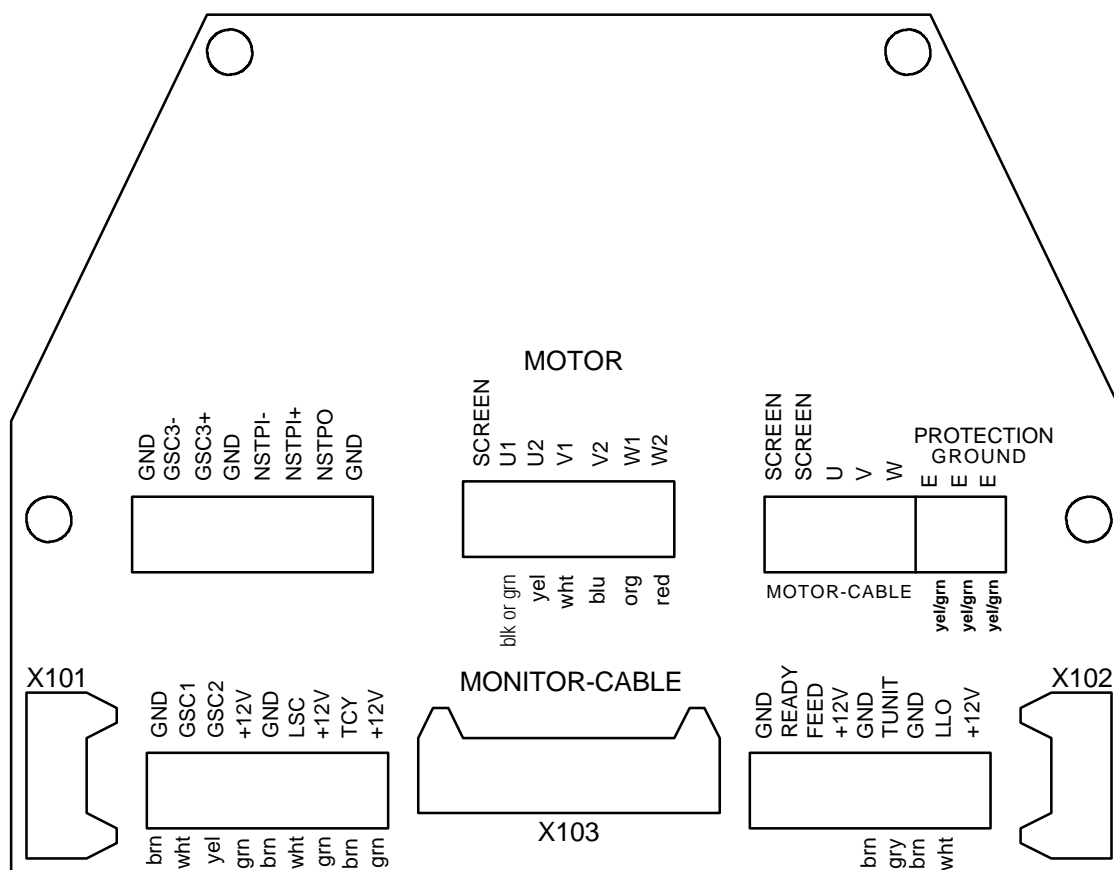

Figure 19: Connector print

6.10 Control signals for external units

The signals FEED and READY are used to control external units.

6.10.1 FEED

The FEED signal indicates that the labeler is dispensing. This means that the stepper motor is turning. With this signal an external flat printing unit can be controlled. See therefore figure 20.

6.10.2 READY

The signal READY is used to signal the Collamat that a connected peripheral device like hot-stamp or flatprinter is ready. If the signal is active, this means the NPN-output of the device is pulled to GND, labelling is not possible. An error message is then displayed.

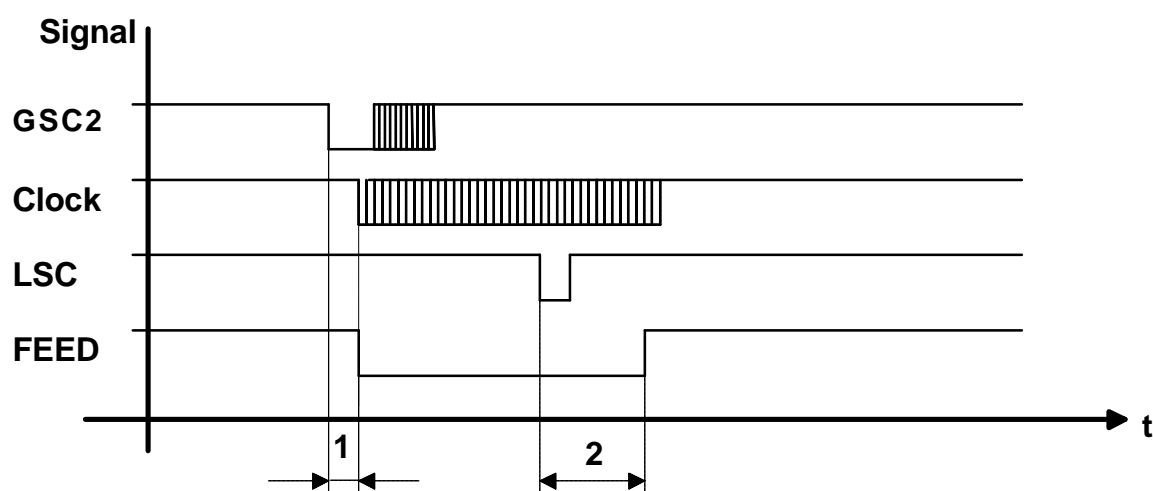

Figure 20: Timediagram of the GSC, LSC and FEED signal

1. Speed dependent position delay
2. Length of the predispensing

All signals are Open-Collector to ground and capable to drive a maximum load of 100 mA. See figure 25.

7 Signals and connector pin assignments

This chapter describes the signals of the Collamat 8600. All in- and outputs are described functionally and electrically. Also the pin assignments are described.

All in- and outputs are equipped with filterelements to prevent electromagnetic interference.

These components also prevent interference caused by electrostatic discharge. The interference can lead to malfunction of the Collamat 8600. Anyway, installing the Collamat 8600 you have to consider the rules concerning RMI and ESD to prevent these interferences.

7.1 Inputs

There are two different kind of inputs:

- **Photocoupler inputs** : isolated by photocouplers
- **Comparator inputs** : with ground referenced comparator

7.1.1 Photocoupler inputs

The photocoupler inputs are used to connect different equipment which may have a different grounding or another ground reference. So circulating ground current through the inputs is not possible and interference due to this can not take place. All photocoupler inputs are protected against wrong polarity and overvoltage. Figure 21 shows the schematics of the photocoupler inputs:

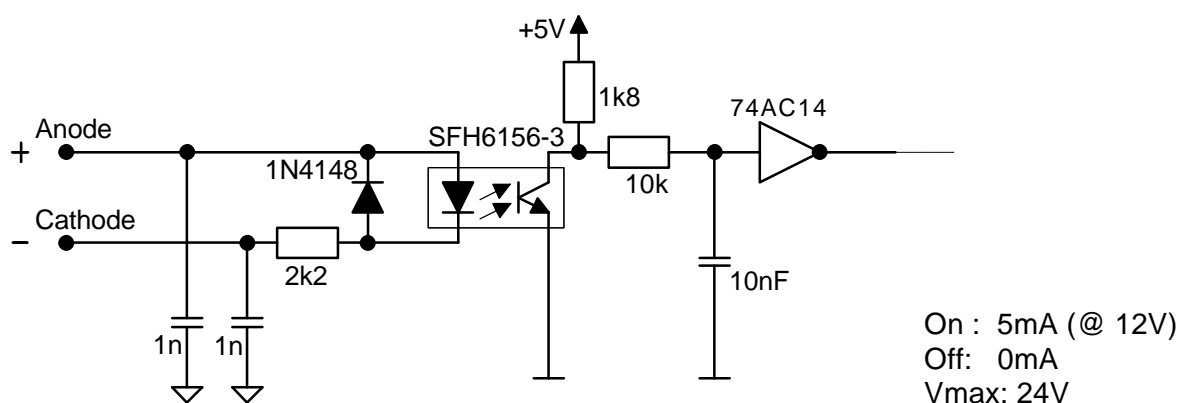

Figure 21: Photocoupler input diagram

The input is active when a current higher than 5mA (at 12V) runs through the photocoupler LED. The maximum input voltage is 24V.

The following input signals are equipped with photocouplers:

- **GSC3** Goods scanner for nonstop labelling or external counter
- **NSTPI** Control signal for the nonstop labelling
- **STOP** Control input for an external controller

7.1.2 Comparator inputs

The comparator inputs are used to connect the peripheral unit signals generated by the dispenser. These are connected with the **DISPENSER**-plug through a cable to the monitor. The signals are connected inside of the traction unit.

The inputs are protected against wrong polarity and they are active while being pulled to GND (0V, ground). (The peripheral units of HM Collamat AG have NPN-outputs to 0V). Figure 22 shows the input diagram of the comparator inputs:

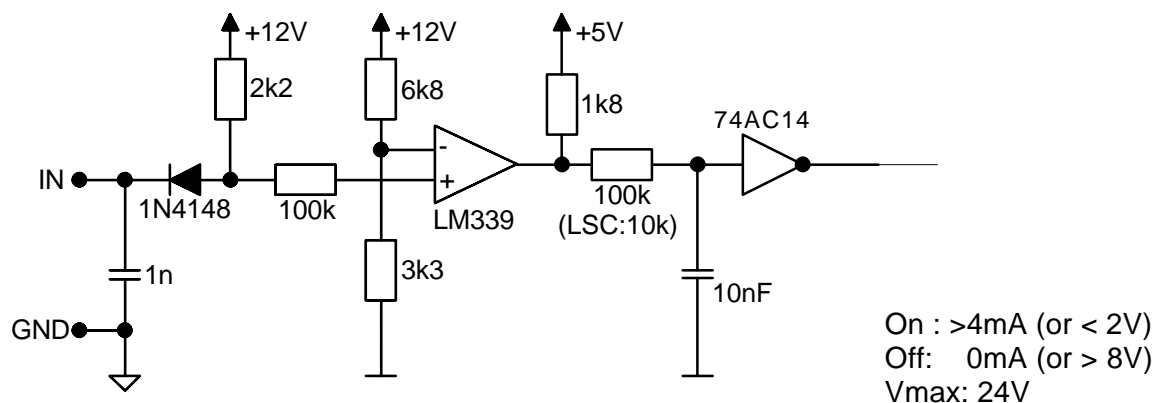

Figure 22: Comparator input diagram

The inputs are active while a current of minimum 4mA is pulled to GND.

The following input signals are equipped with comparators:

- **GSC1** Incremental encoder or speedmeasuring scanner
- **GSC2** Goods scanner
- **LSC** Label scanner
- **TUNIT** Traction unit, paperend sensor
- **READY** READY-signal from the flatprinter
- **LLO** Paperstock control, unwinder empty

7.2 Functional description of the inputs

7.2.1 Goods scanner GSC1 and GSC2 (Good Scanner)

The inputs GSC1 and GSC2 are used to scan the goods. For all three speedmeasuring modes (fixed speed, measuring and incremental) GSC2 is used for scanning the goods. GSC1 is used for the speedmeasuring.

- For the fixed speed GSC1 is not used.
- For the scanning with the measuring scanner, GSC1 is the first activated scanner, seen in transportation direction. (GSC1 must first be interrupted). The mechanical distance to the second scanner can be programmed on the control panel. (The distance must be in the range between 10 mm and 100 mm).
- For the speed measuring with an incremental encoder GSC1 is connected to the NPN output of the encoder.

7.2.2 Goods scanner GSC3

The input **GSC3** is used to count the goods in the nonstop labelling mode. The input also can be used to count goods or events. Therefore the counter must be programmed to EXTERNAL. The input GSC3 will be connected in the traction unit. Figure 23 shows how to connect the GSC3 input.

7.2.3 Control input NSTPI (NonSToP In)

The **NSTPI** input is used for the connection of two Collamat in the nonstop labelling mode. The wiring of the nonstop mode is described in the chapter nonstop labelling. This input is connected inside of the traction unit. Figure 23 shows how to connect the NSTPI-input.

7.2.4 Control input STOP

The **STOP** input is used to stop or start the Collamat. It has the same function like the RUN/STOP key on the control panel. If the signal is activated while the Collamat is stopped, the Collamat will be started (RUN) and vice versa.

The relais contacts are activated according to the momentary mode. The counting of the goods will be continued anyway. Error messages will not be cleared. The signal must be connected to the **CONTROL SIGNALS** connector.

Figure 23 shows how to connect the STOP input.

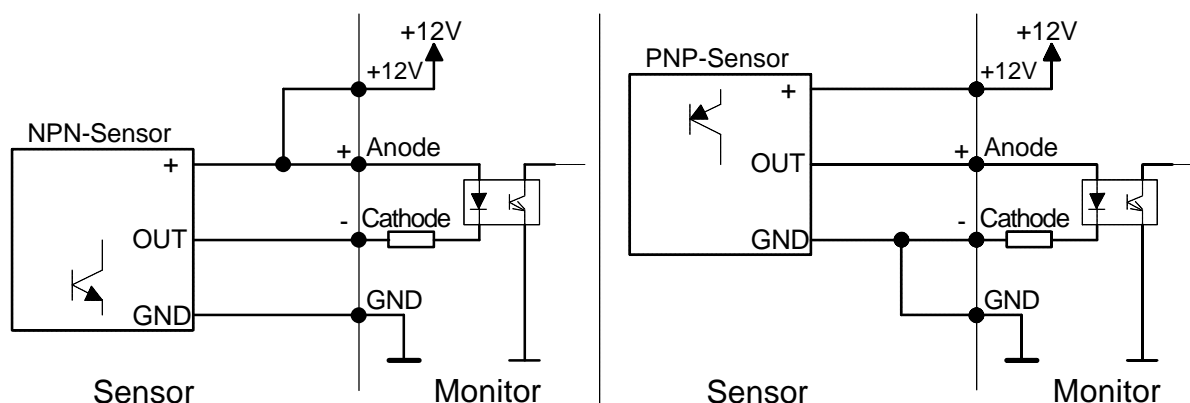

Figure 23: Connection of photocoupler inputs

All comparator inputs are taken to the **DISPENSER** connector. From there the signals go to the traction unit. The peripheral units are all connected to the traction unit.

7.2.5 LSC (Label SCanner)

The **LSC** input is connected to the label scanner. This input has a fast response time for accurate scanning of the label position while transportation. As label scanners all NPN- sensors can be connected to the connector box.

7.2.6 TUNIT (Traction UNIT)

The signal **TUNIT** is used for the supervision of the traction unit. In the traction unit two signals are observed. The first sensor observes the locking sensor of the tractionroller. The second sensor observes the paperend. For the paperend sensor an alternative sensor may be used.

7.2.7 READY

The signal **READY** is used to signal the Collamat that a connected peripheral device like hot-stamp or flatprinter is ready. If the signal is active, this means the NPN-output of the device is pulled to GND, labelling is not possible. A warning or error message is then displayed.

7.2.8 LLO (Label LOw)

The signal **LLO** is used to observe the diameter of the winder. The standard sensors of HM Collamat AG are equipped with NPN-outputs and are connected to the traction unit.

7.3 Outputs

We also have two different kinds of outputs:

- Isolated outputs
- Open-Collector outputs

7.3.1 Isolated outputs

These outputs are completely isolated to the monitor. There are three relais outputs and one photocoupler output. The relais outputs are capable to drive signaling lamps or an external PLC. Figure 24 shows the electrical diagram of the isolated outputs.



ATTENTION:
The relais outputs must not be used to switch risky or selfdriven units.

If the relais outputs are active the contacts A and C are connected together. If not active R and C are connected together. See also figure 24.

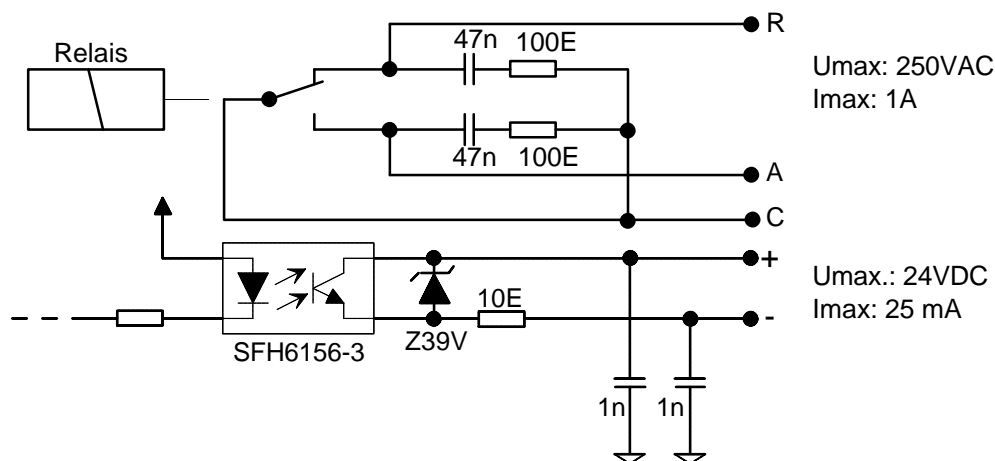

Figure 24: Floating outputs

The following outputs are floating:

- **RUN** Relais output indicates RUN mode
- **NOK** Relais output indicates a WARNING message
- **ERROR** Relais output indicates an ERROR message
- **IFEED** Photocopler, isolated FEED-signal

7.3.2 Open-Collector outputs

The Open-Collector signals are used to switch and control external units. Figure 25 shows the electrical diagram of these outputs. The outputs are equipped with an internal free wheeling diode. If an inductive load is switched an additional external diode is necessary.

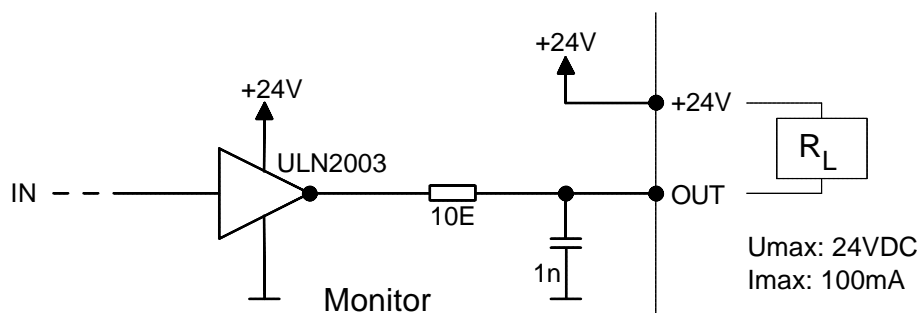

Figure 25: Open-Collector output

The following Open-Collector outputs are available:

- **FEED** Indicates that the traction motor is turning
- **CLOCK** Steppermotor clock for synchronizing external units
- **NSTPO** Nonstop control signal

7.4 Functional description of the outputs

7.4.1 Mode indicator RUN

The **RUN** relais output indicates the RUN or Stop mode of the labeler. The output is activated while the Collamat is in the labelling mode. If the Collamat is stopped the relais output is not activated.

Example: The output RUN can be used to activate a green lamp.

7.4.2 Warning signal NOK (Not OK)

The **NOK** relais output indicates a warning condition. The cause is displayed on the control panel. To confirm and clear the NOK signal, first the cause of the warning must be eliminated. Then the ENTER key must be pressed on the control panel.

Example: The output NOK can be used to activate a yellow lamp.

7.4.3 Error signal ERROR

The **ERROR** relais output indicates an error condition. The cause is displayed on the control panel. To confirm and clear the ERROR signal first the cause of the error must be eliminated. Then the ENTER key must be pressed on the control panel.

Example: The output ERROR can be used to activate a red lamp.

7.4.4 Connection of a signalisation to the monitor

To connect the signal lamps like described above, it can be wired like shown in figure 26. The connection is made to the CONTROL SIGNALS connector.

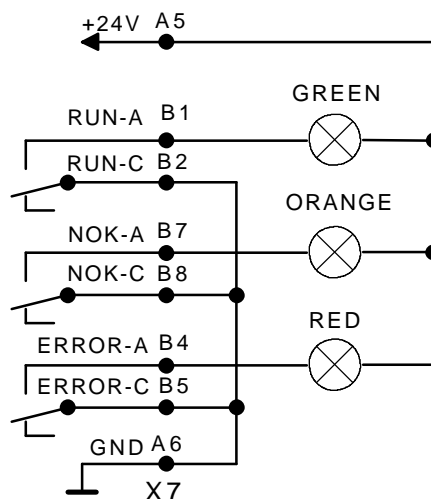

Figure 26: Connection of a signalisation lamp

7.4.5 Signal FEED, IFEED

The signal **FEED** is always active when the stepper motor is turning. This signal indicates an external printing unit that the paper is moving or stopped. The flatprinter analyses the rising edge of this signal for the printing action. The time diagram of the FEED-signal is shown in figure 47.

The signal **IFEED** is a copy of the FEED signal. It is completely isolated by a photocoupler from the electronic parts. This signal can control a strange printing unit completely floating. Thanks to the photocoupler the signal can be used for NPN or PNP inputs. The polarity of the IFEED signal can be adjusted on the control panel. **NORMAL** means that the signal is with the same polarity of the FEED signal. **INVERSE** means that it is inverted to the FEED signal.

7.4.6 Stepper motor clock CLOCK

The signal **CLOCK** can be used to synchronize an external device (e.g.. Ink-Jet or Thermal Transfer printer) with the stepper motor.

7.4.7 Control output NSTPO (NonSToP Out)

The signal **NSTPO** is used to link two Collamat 8600 for the nonstop mode. The wiring diagram is shown in the chapter nonstop.

7.5 Connector layouts of the monitor C8600

7.5.1 Connector X3, DISPENSER

To this connector the control cable to the traction unit is attached. The signals of this connector are used especially to control the dispenser and its units.

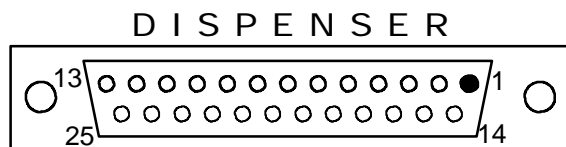

Pin	Name	In/Out
1	GND	
2	GND	
3	GSC2	I
4	LSC	I
5	TUNIT	I
6	READY	I
7	GND	
8	GND	
9	LLO	I
10	GSC1	I
11	GND	
12	GND	
13	GND	

Pin	Name	In/Out
14	+12V	
15	+12V	
16	CLOCK	O
17	FEED	O
18	TCY	O
19	GND	
20	NSTPO	O
21	GSC3-	I
22	GSC3+	I
23	+12V	
24	NSTPI+	I
25	NSTPI-	I

Pin assignment of the connector DISPENSER



ATTENTION:
For the connection of the dispenser signals a shielded cable must be used.
The cable must not be placed near power electronic devices. See also chapter Cabling.

7.5.2 Connector X7, CONTROL SIGNALS

On the CONTROL SIGNALS connector the upper row is used to access three relais contacts for signalisation purpose. The lower row supplies a 24V voltage for external signal lamps. The maximum current for the 24V is 200 mA.

CONTROL SIGNALS

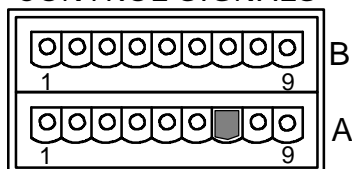

PHOENIX CONTACT MDSTB 2,5/9-G1-5,08

Pin	Name	In/Out
1	RUN A	O
2	RUN C	O
3	RUN R	O

Pin	Name	In/Out
4	ERROR A	O
5	ERROR C	O
6	ERROR R	O

Pin	Name	In/Out
7	NOK A	O
8	NOK C	O
9	NOK R	O

Pin assignment of the upper connector row CONTROL SIGNAL

Pin	Name	In/Out
1	STOP+	I
2	STOP-	I

Pin	Name	In/Out
3	IFEED+	O
4	IFEED-	O

Pin	Name	In/Out
5	+24V/200mA	
6	GND	

Pin assignment of the lower connector row CONTROL SIGNAL

7.6 Connector layouts traction unit C8600

7.6.1 Connector X101, X102 BUS

The connectors X101 and X102 are used for the connection of the buscable to the peripheral units on the modular rail. The buscable must be located inside the rail to prevent RMI.

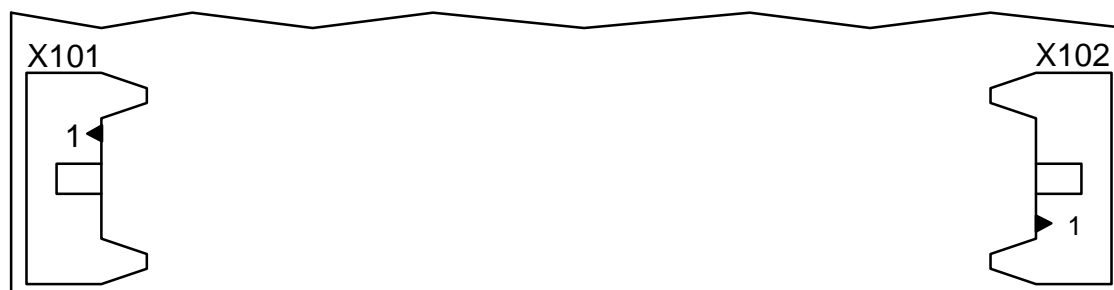
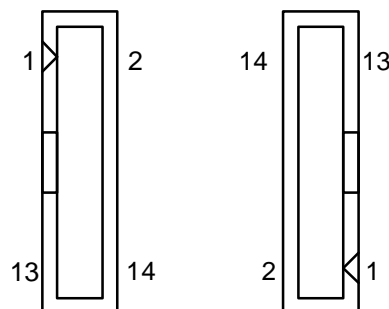

Figure 27

Connector X101				Connector X102			
Pin	Signal	Pin	Signal	Pin	Signal	Pin	Signal
1	+12V	2	+12V	1	GND	2	GND
3	READY	4	FEED	3	nc.	4	nc.
5	LSC	6	GSC1	5	CLOCK	6	nc.
7	TCY	8	GSC2	7	GSC2	8	TCY
9	nc.	10	CLOCK	9	GSC1	10	LSC
11	nc.	12	nc.	11	FEED	12	READY
13	GND	14	GND	13	+12V	14	+12V



7.7 Connection diagram

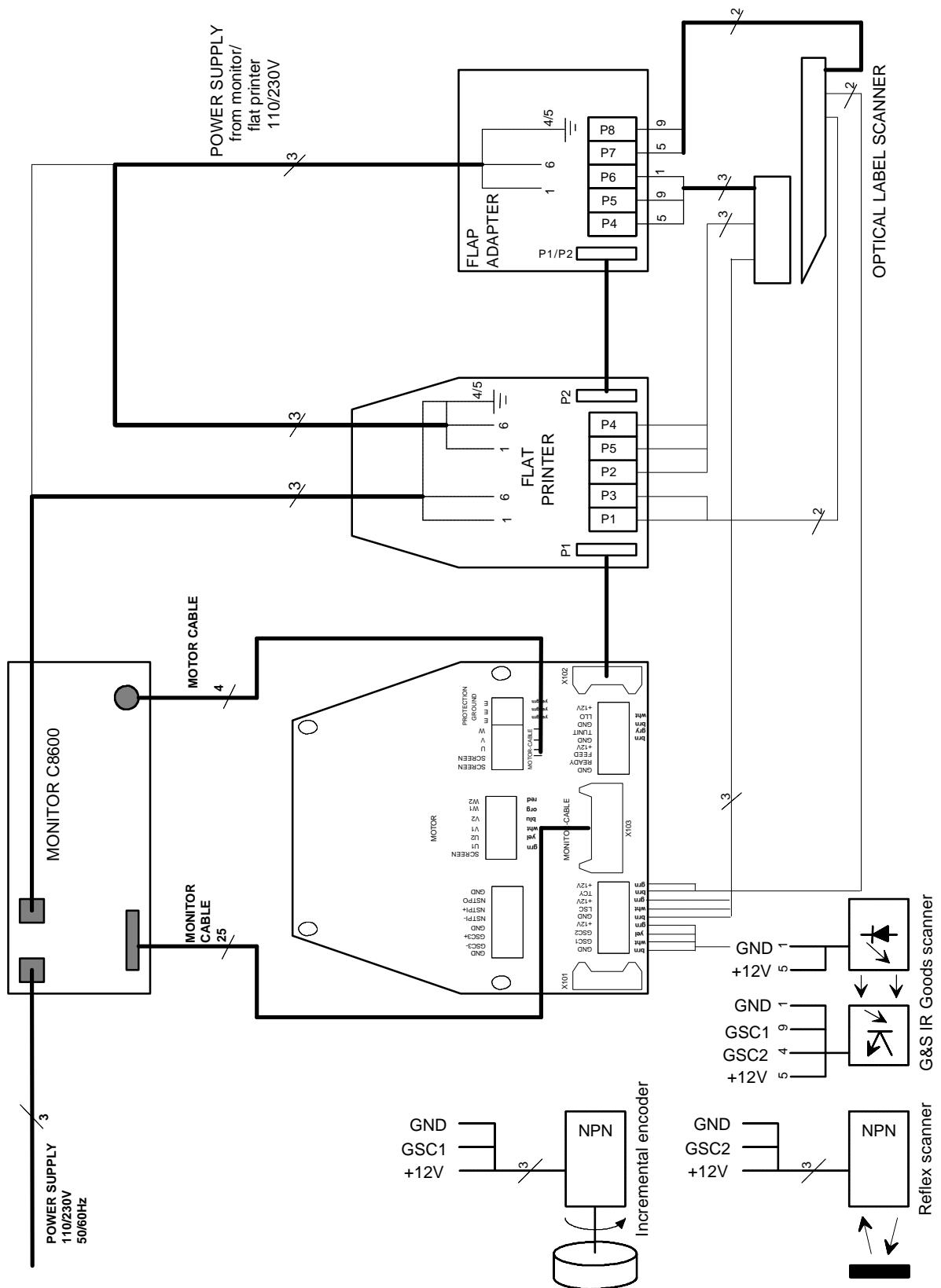

Figure 28

7.8 How to connect a goods scanner

The goods scanners and incremental encoders are connected to the GSC1 and GSC2 connectors. Figure 29 shows the connection of the standard HM Collamat AG IR goods scanner:

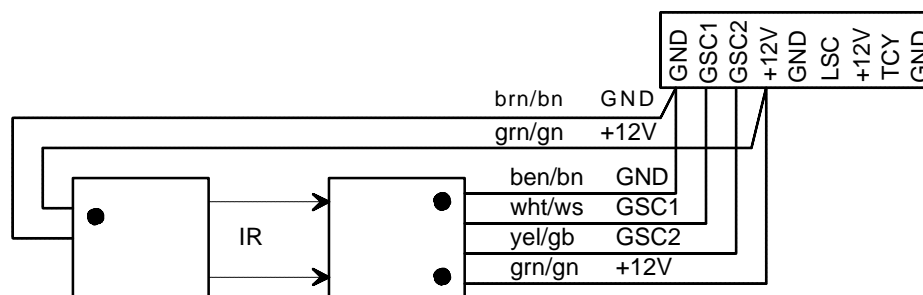

Figure 29: Connection of the G & S IR goods scanner

Figure 30 shows the connection of a NPN-scanner:

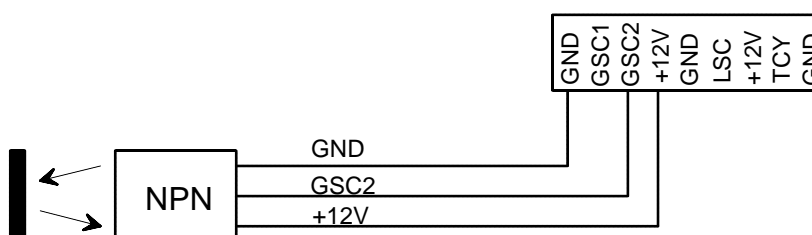

Figure 30: Connection of a NPN-scanner

Figure 31 shows the connection of a NPN-incremental encoder:

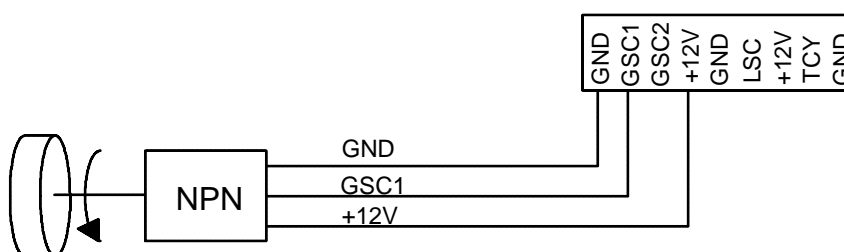

Figure 31: Connection of a NPN-incremental encoder

7.9 Goods scanners

7.9.1 Speed measuring CS IR goods scanner

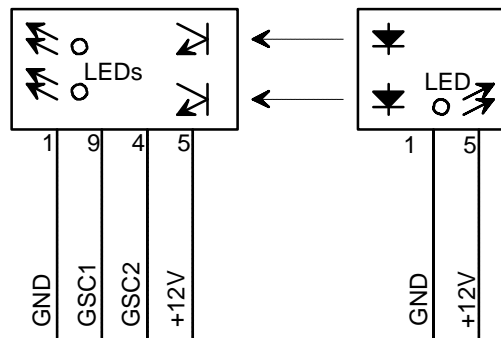

Figure 32

7.9.2 NPN Reflexscanner, Lightbeam scanner

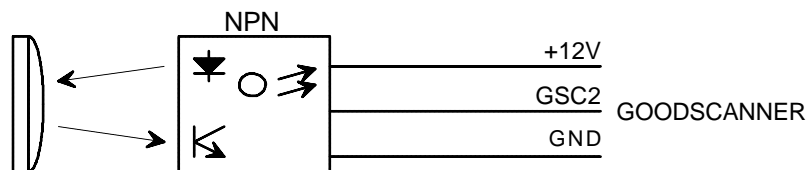

Figure 33

7.10 Optical label scanner

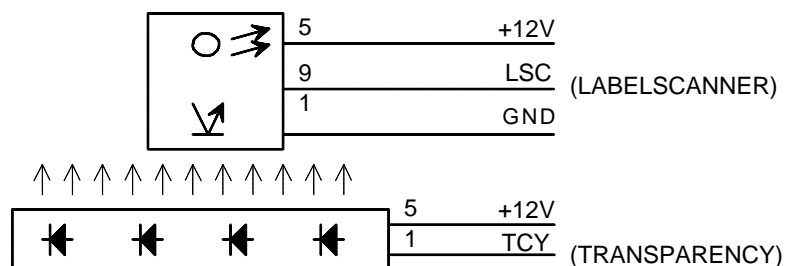

Figure 34

7.11 Signalcable connection

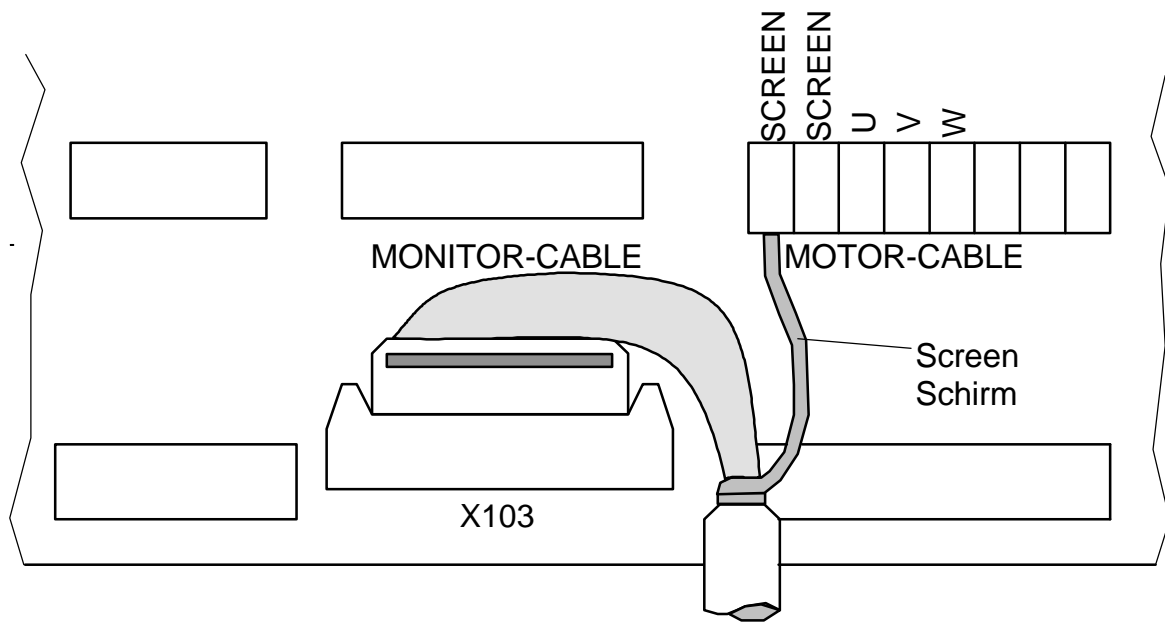

Figure 37: Connection of the signalcable

7.12 Adapter with magnet

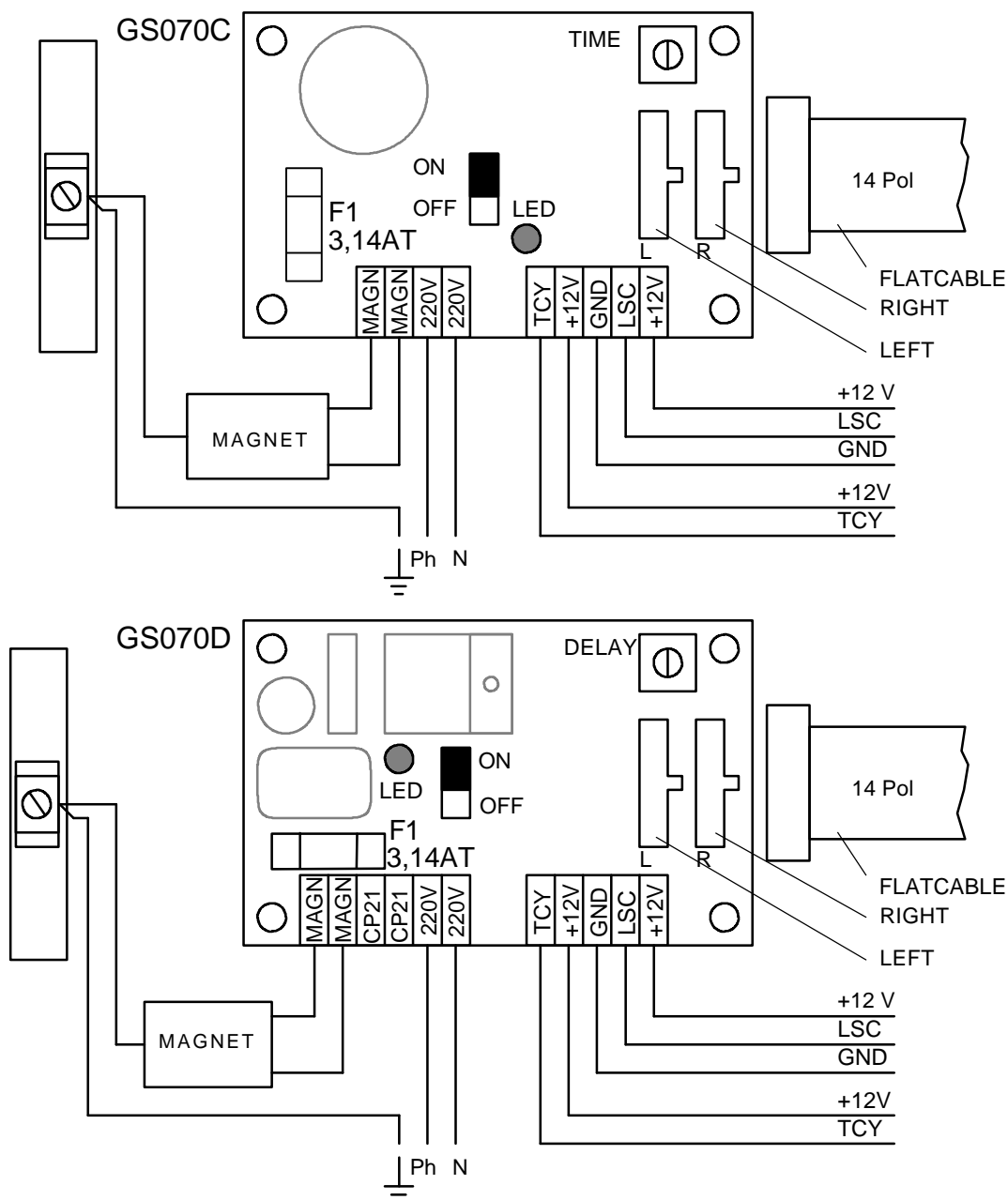

Figure 39

The mains voltage must be connected inside of the flap printer or inside of the dispenser. See also connection diagram figure 28.

The factory setting of the trimmer TIME is on MINIMUM. The trimmer is used to set a delaytime for the releasing of the magnet.

The terminals CP21 are used to connect the synchronous motor of the wrap around adapter



ATTENTION:
Plugging in of the LEFT or RIGHT connector of the flat-cable to the wrong plug can damage the magnet adapter board.

7.13 Flatprinter board

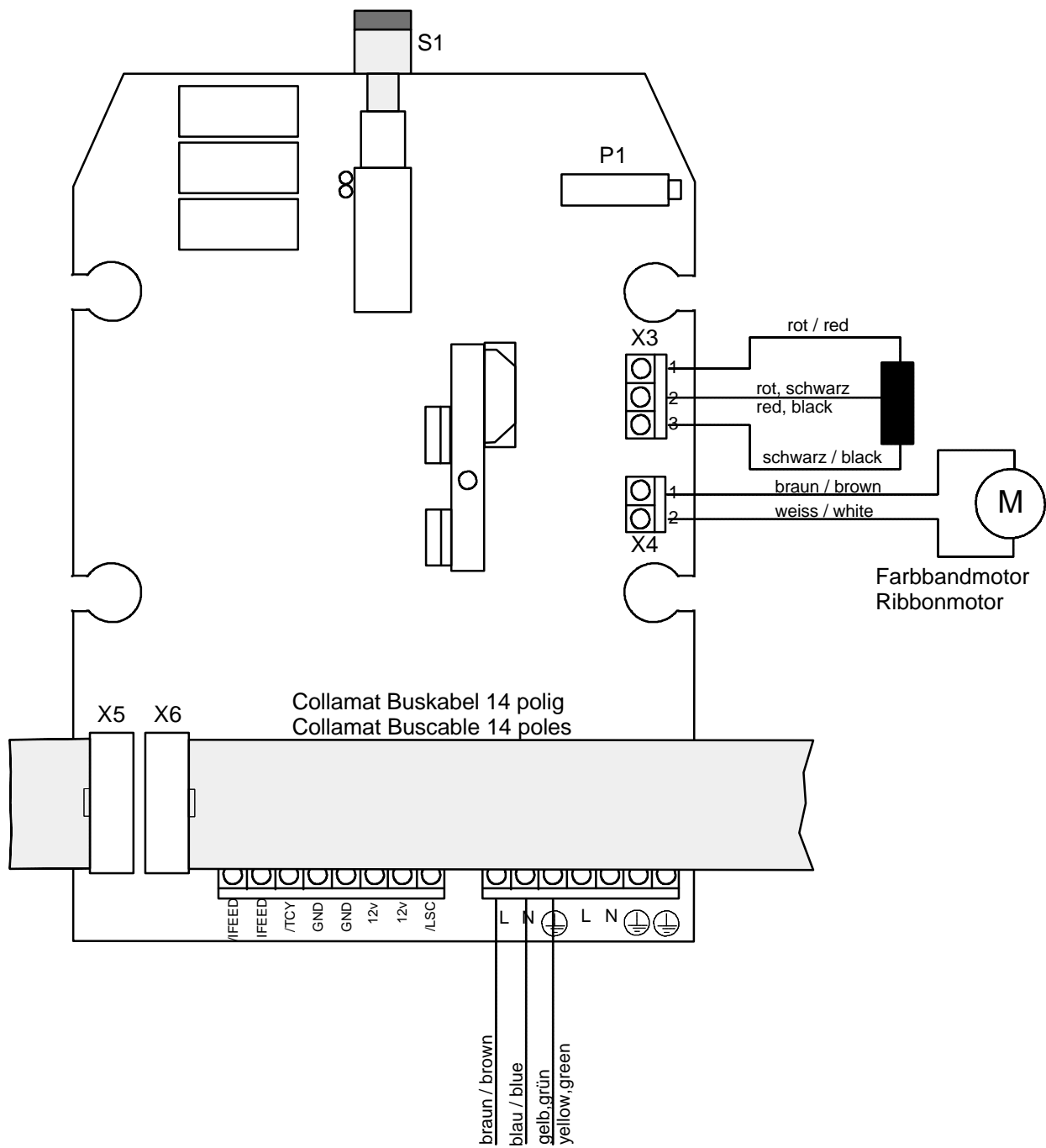

Figure 39

8 Nonstop labelling

When using two Collamat 8600 it is possible to label goods with no down time. For this purpose the two monitors must be connected together by an electrical link. The necessary links are shown in figure 40. The placement of the two Collamat to each other is shown in figure 41.

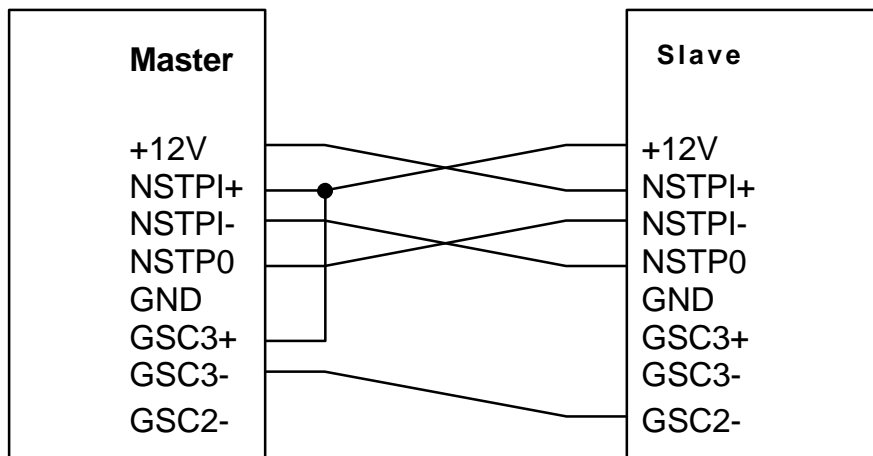

Figure 40: Connections for nonstop labelling

Not shown is the connection of a possible connected speedmeasuring equipment using an incremental encoder, and the goods scanner of both Collamat. For the speed measuring one incremental encoder could be used for both Collamat together. Notice also that the goods scanner GSC2 of the slave is connected in parallel to the GSC3 input of the master.

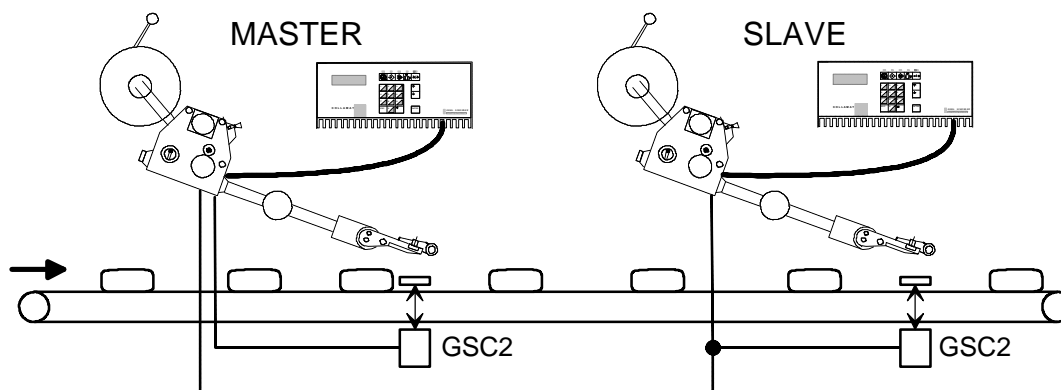

Figure 41: Placement of the two Collamat

8.1 Proceeding

The nonstop labelling is supervised and controlled by the master. Goods passing GSC2 of the master are counted up. Passing GSC2 of the slave the goods are counted down. If the master is unable to label the goods, it gives the grant to the slave at the moment when the first unlabelled good reaches the GSC2 scanner of the slave.

At this moment the slave starts the labelling. Now the cause of the stop of the master can be serviced. The slave labels the goods until it is unable to label because of any reason. Now the slave signals the master to start labelling. The master starts immediately to label the goods. At this moment both Collamat are labelling for a while. When the first labeled good arrives at the GSC2 of the slave, the slave stops labelling. Now the cause of the stop of the slave can be serviced.

The master always has the control over the goods which are labeled on which Collamat. In the display of the control panel it is possible to display the goods count of the goods between the two GSC2 scanners of the two Collamat. If an error occurs which causes a stop of both Collamat, all goods in between of both GSC2 scanners must be removed. Then the NONSTOP COUNTER must be cleared on the control panel of the master.

8.2 Setting up of the Nonstop mode

When the wiring of the Nonstop mode is made, the installation must be set up as follows:

- Stop the conveyor or the goods transportation
- Remove all the goods in between of the two GSC2
- Set both monitors to STOP
- Set up the two labelers
- Choose Nonstop mode MASTER on the master
- Choose Nonstop mode SLAVE on the slave
- Set monitor master to RUN
- Set monitor slave to RUN
- Start the conveyor or the goods transportation

The goods are now labeled in the Nonstop mode. If an error occurs which causes a stop of a Collamat the following proceeding is necessary:

- Service the erroneous condition on the stopped Collamat
- Confirm the error message on the monitor with the ENTER key

If an error occurs which stops both Collamat, first the error condition must be serviced. Then all the goods in between the two GSC2 sensors must be removed. The nonstop counter must be cleared on the master.

For the supervision and setting up the Nonstop mode, in the free selectable display, the counter of the goods in between the two GSC2 scanners, can be displayed.

If a position value or a goods suppression is set, it will be considered by the monitor while labelling. The distance of the GSC2 to the peeling edge must be in this case the same on both labelers.

9 Speed measuring

9.1 Incremental encoder

The electrical connection of an incremental encoder is described in the chapter 'Connection of the goods scanners'. Now the mechanical attachment of the conveyor to the encoder will be described. If the speed measuring is done by an incremental encoder, on the control panel the step width must be programmed so that the speed measuring is made correctly. The step width is the traveling way of a good in between two encoder steps. Figure 42 shows an example how to calculate the step width:

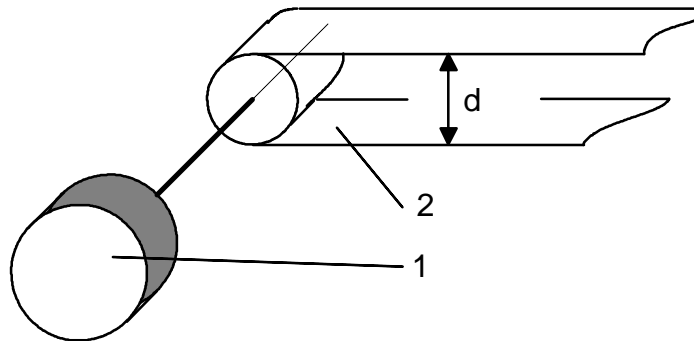

Figure 42: Incremental encoder

Example:

The incremental encoder 1 gives 200 pulses per revolution. It is attached directly to the shaft of the conveyor 2. The diameter d is 100 mm. Calculation:

$$\text{Step} = \frac{d * \text{Pi}}{\text{Pulse}} = \frac{314 \text{ mm}}{200} = 1.57 \text{ mm}$$

9.2 Measuring goods scanner

The electrical connection of the measuring goods scanner is described in the chapter 'Connection of the goods scanners'. If the speedmeasuring is done by a measuring goods scanner, on the control panel the distance L must be programmed so that the speedmeasuring is made correctly. Figure 43 shows the placement of the scanners:

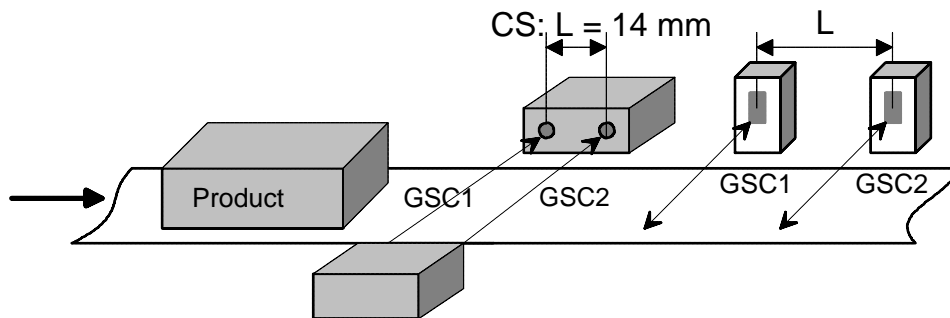

Figure 43: Measuring goods scanner

10 Motor and motorcable



Attention:

- The motor never must be dismantled !
- For safety reasons and in order to guarantee interference suppression, the motor has to be connected to a ground conductor !
- Stepermotors heat up during operation !
- When connecting or disconnecting the motor, the monitor must be switched off !
- When working on the motor, the monitor must be disconnected from mains !

10.1 Motorcable

The motorcable is connected to the connector MOTOR of the monitor.

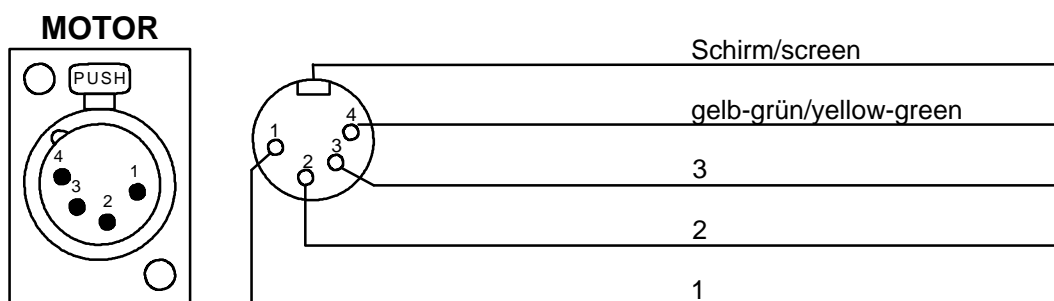

Figure 44: Motorcable

10.2 Connection of the motorcable

The motorcable is connected inside of the traction unit. The numbered wires must be connected to the terminals W, V and U. The screen must be connected to the SCREEN terminal. See also figure 45:

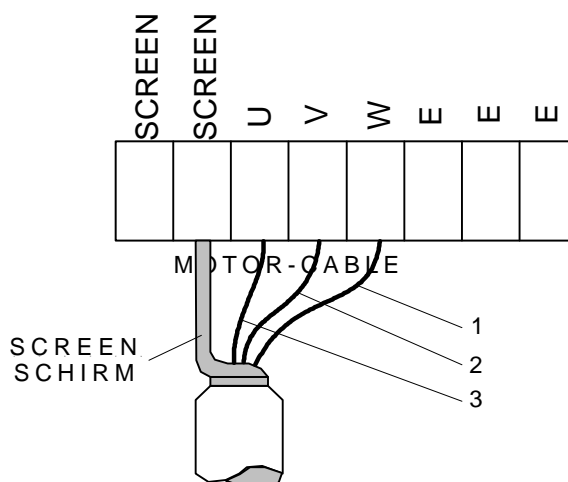

Figure 45

11 Control of external devices

11.1 Control of a Hotstamp with the IFEED signal

The connection of a hotstamp printer to the IFEED signal is described below. On the CONTROL SIGNALS connector the IFEED signal can be used. It can be connected for two different types (NPN or PNP) of hotstamp inputs. Figure 46 shows the connection of different hotstamps. Figure 47 shows the timing diagram.

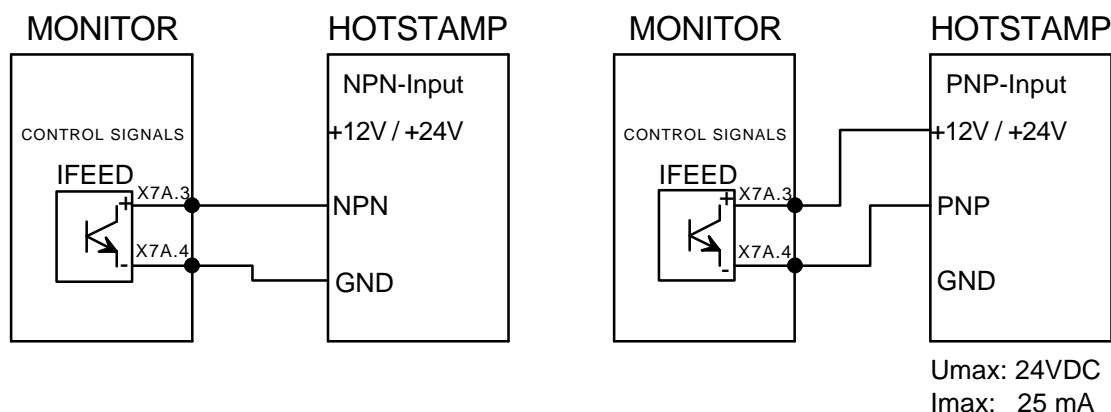

Figure 46: Connection of IFEED

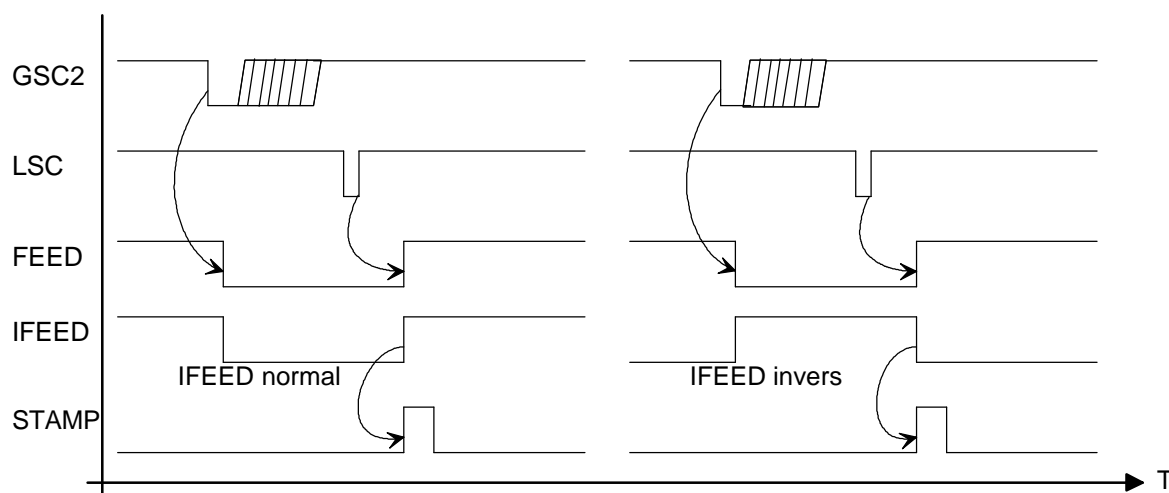

Figure 47: Timing diagram

Dependent on the manufacturer, the polarity of the triggering signal of the hotstamp must be changed. This adjustment is to be set in the configuration menu **IFEED POLARITY** to normal or **inverse**. See also figure 47.

12 Monitortest with a diagnostic connector

In the firmware of the Collamat 8600 there is a selftest function for the monitor electronics. This test only may be successful with a diagnostic connector attached to the three connectors on the back plane of the monitor.

Figure 48 shows the diagram of the wiring of this connectors:

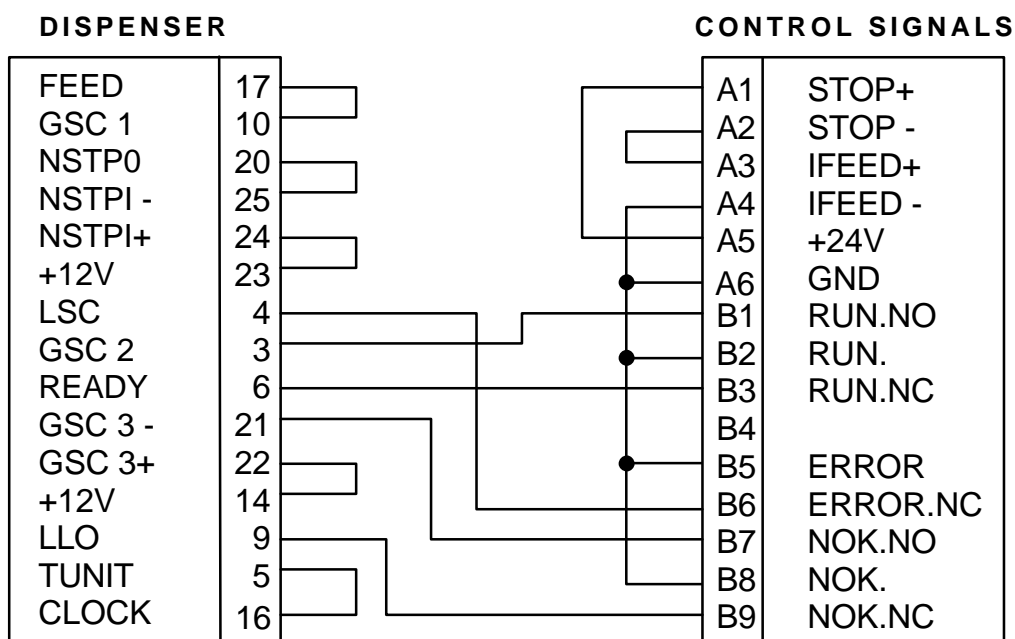

Figure 48: Diagnostic connector

13 Cabling and setting up

For a troublefree operation of the Collamat 8600 following items must be observed:

- Trained personnel
- Ambient temperature
- Protection against dirt and dust
- Protection against splashing water
- Installation and setting up of the installation
- Installation and setting up of the Collamat 8600
- Electromagnetic interferences
- Safety regulations and safety requirements

13.1 Cabling

Electromagnetic interferences can lead to non repeatable and not obvious errors while labelling. Often misplaced layout of the cabling, RMI and ESD interferences disturb the labelling. Because of this, the following rules must be observed for the cabling:

- Separated mains and signal cables
- Use shielded cables
- All units must be grounded
- Connect only devices which meet the RMI standards
- Use power filtering units in interfered environments and interfered mains supplies

13.2 Setting up

The setting up must be done carefully by trained personnel. The following items must be observed:

- Visual control of the control unit
 - Are all electrical and mechanical units correctly attached ?
 - Are all connectors accessible ?
- Connect the monitor to mains and switch it on
 - Is the display illuminated ?
 - Does the startup message appear ?
- Turn off the monitor and unplug it from mains
- Set up the winder and unwinder and connect them to the connector box
 - Are the jumpers inside of the winders set correctly ?
- Attach the goods scanner signals to the DISPENSER connector
- Connect the monitor to the mains voltage and turn it on
 - Do the winder turn the right way ?
- Turn off the monitor and unplug it from mains
- Connect the remaining units to the connector box of the Collamat
- Connect the monitor to the mains voltage and turn it on
 - Do the peripheral units work OK ?
- Turn off the monitor and unplug it from mains
- Attach the motorcable
- Connect the monitor to the mains voltage and turn it on
 - Does the motor work in the MOTORTEST-menu ?
 - Is the turning direction OK ?
- Thread the paperweb and adjust the label scanner
- Dispense a label by the control panel
 - Is it dispensed correctly ?
- Connect the goods scanners (and possible incremental encoder)
- Dispense a label by the goods scanner
 - Watch to the error messages on the display

14 Password

In case of a lost password the firmware gives two procedures for recovery. One procedure uses the keyboard on the front panel. This procedure causes data loss. The other procedure uses a keyswitch but the monitor must be opened.

14.1 By keyboard

First switch power off. Then hold the ENTER-key while turning power on. The following message is displayed:

```

Clear memory !

Password      ####
Discontinue: [ESC]
  
```

Now type in **4148**. The Collamat will clear now the password to **0000**. The data of program number **32** will be set to default values and it will start up with program **32**.

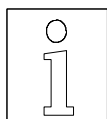

Note:
This function is available since firmware 1.20.
Version 1.10....1.13 clears program 1.

If you type **4147** instead **ALL** programs are set to default values the password is also cleared and program **1** is selected.

This procedure is also helpfull to restart a completely misprogrammed Monitor which hangs after power on.

14.2 By keyswitch



DANGER:
Before opening the monitor unplug the mains plug. Charged capacitors inside the monitor may lead to shock hazard. After unplugging wait at least 10 seconds before opening the monitor.

For this procedure the monitor must be opened. On the interfaceprint (see figure 17) two jumpers **J1** and **X9** must be set. Now after power on in the Configuration menu User level the password can be changed.

15 Fuses

Fuse	Rating	Part Number
Monitor	110/120V: 10 AT	7403.0833
	220/230/240V: 5 AT	7403.0822
Interface F1	3.15 AT	7403.1216
Interface F2	2.5 AT	7403.0277

16 Glossary

16.1 Short cuts

ESD	E lectro S tatic D ischarge
RMI	R adio M agnetic I nterference
GND	G rou N D
IR	I nfra R ed
LCD	L iquid C rystal D isplay
LED	L ight E mitting D iode
nc	not connected
RS232	Standard serial data exchange protocol

16.2 Signals

ERROR	Errorsignal caused by any error of the Collamat
FEED	Signal indicating the labelling process
GND	G rou N D
GSC	G oods S Canner
IFEED	Isolated FEED signal
LLO	L abel L ow signal indicating the end of the label stock
LSC	L abel S Canner
nc	not connected
NOK	N ot OK , something not OK
NSTPI	N on S To P I N-put
NSTPO	N on S To P O U T -put
READY	READY signal from peripheral units
RWF	R e W inder F ull
TCY	T ransparen C Y, Control current for the label scanner IR-diodes
TUNIT	T raction U N I T, signal that supervises the traction unit

16.3 Terms

Stopping accuracy: Accuracy of the paper transportation

Unwinder: Device that carries the full paperweb rolls and unwinds it

Adapter: Part of the labeler. Here the label is peeled of the paperweb by pulling it over a sharp edge

Rewinder: Device that takes the empty paperweb from the traction unit and rewinds it

CE-Mark: Certification for the European market, means: Conformité Européenne

Collamat: Brand name for a labeler built by HM Collamat AG

C8600: Labeler type C8600

GSC: Goods SCanner

Flap adapter: Adapter which moves to the product during the labelling

LSC: Label SCanner

LC-Display, LCD: Liquid crystal display

Machine status: Working mode of the Collamat. E.g.: Stop, OK, ERROR

Monitor: Controlbox containing all electronic boards of the Collamat

Position: Sticking position of a label on the good

Predispensing: Predispensing of a label on the peeling plate

Motorstep: Traveling way of the label for one motorstep

Dispensing speed: The speed of the goods to which the labels are sticked

Speed: See also dispensing speed

Startfrequency: Highest possible frequency for a stepper motor to start moving without loss of steps

Traction Unit: Part of the dispenser in which the paperweb is pulled

17 Technical data

Dispenser general data (standard values)

System	Units	C8610	C8620
Version		right/left	
Dispensing speed	Incremental Encoder Measuring Scanner Fixed Speed	0-50 0.5-50 3.0-50	0-50 0.5-50 3.0-50
Min. label width	mm	10	
Max. width of the paperweb	mm	95	160
Min. label length	mm	10	10
Min. label length @ max. dispensing speed	mm	20	
Stop accuracy	mm	@ 40 m/min \pm 0.5	
Minimal gap for optical scanner	mm	2	
Minimal gap for mechanical scanner	mm	2	
Max. diameter of paperroll	mm	250/350	
Max. weight of paperroll	kg	10	
Noise figure max.	dB(A)	< 70	

Traction unit

System	C8600	
Driver	3-Phase stepper motor 500 steps	
Motor voltage	120V	
Max. phase current	5.0 A	
Type of protection	IP40	
Ambient temperature	+5-40 °C	
Ambient humidity	15-90%, non condensing	
Noise figure max.	< 70 dB(A) @ 1 m distance	
System	C8610	C8620
Weight	12 kg	14 kg

Midi-unwinder

Diameter of the roll core	42 mm
Max. outside diameter of roll	350 mm
Max. weight of roll	10 kg
Spring dancer with automatic brake	

Flap adapter

System	C8610	C8620
Max. width of paperweb	95 mm	160 mm
Weight	1.9 kg	2.2 kg
Version	right/left	
Adapter angle	±90°, with adjustable snap-in locking	
Recuperating spring force	adjustable	
Additional press time of adapter	adjustable	
Max. cadence on max. turning angle	20'000 cycles/h	
Max. turning angle	15°	
Ambient temperature	+5-40°C	
Ambient humidity	15-90% non condensing	

Label scanner

Optical label scanner
Mechanical label scanner

Monitor

System	C8600
Mains voltage	110/120V AC, 220/230/240V AC, ±10%
Power consumption	310 VA
Main fuse	120V : 8AT, 230V : 4AT
Display	LCD, 4 lines, 20 characters each
Dimensions (LWH in mm)	375 * 305 * 155 mm
Ambient temperature	+5-40°C
Max. ambient humidity	15-90% non condensing
Type of protection	IP40
Weight	approx. 15.5 kg

**The information in this handbook reflects the state
of the publication date.
We reserve the right to make design modifications.**

17.1 Dimensions - systemdesign

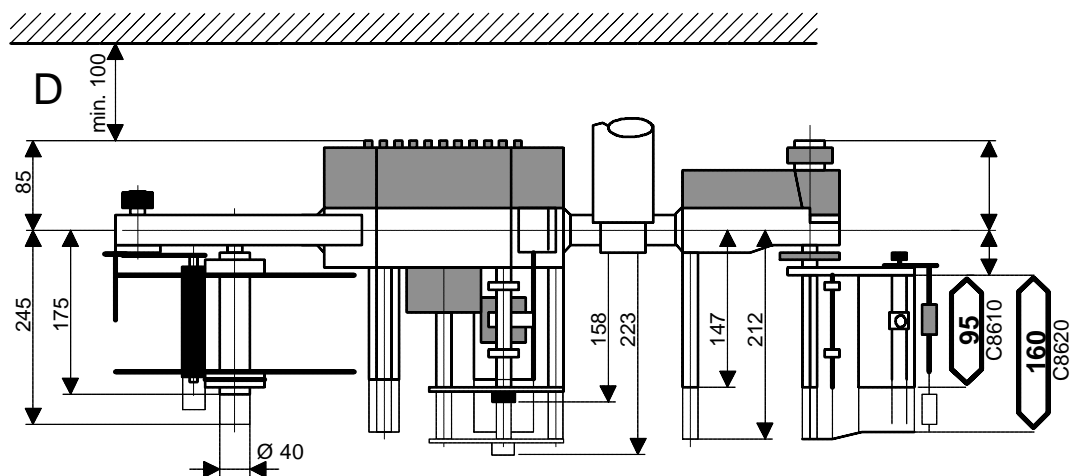
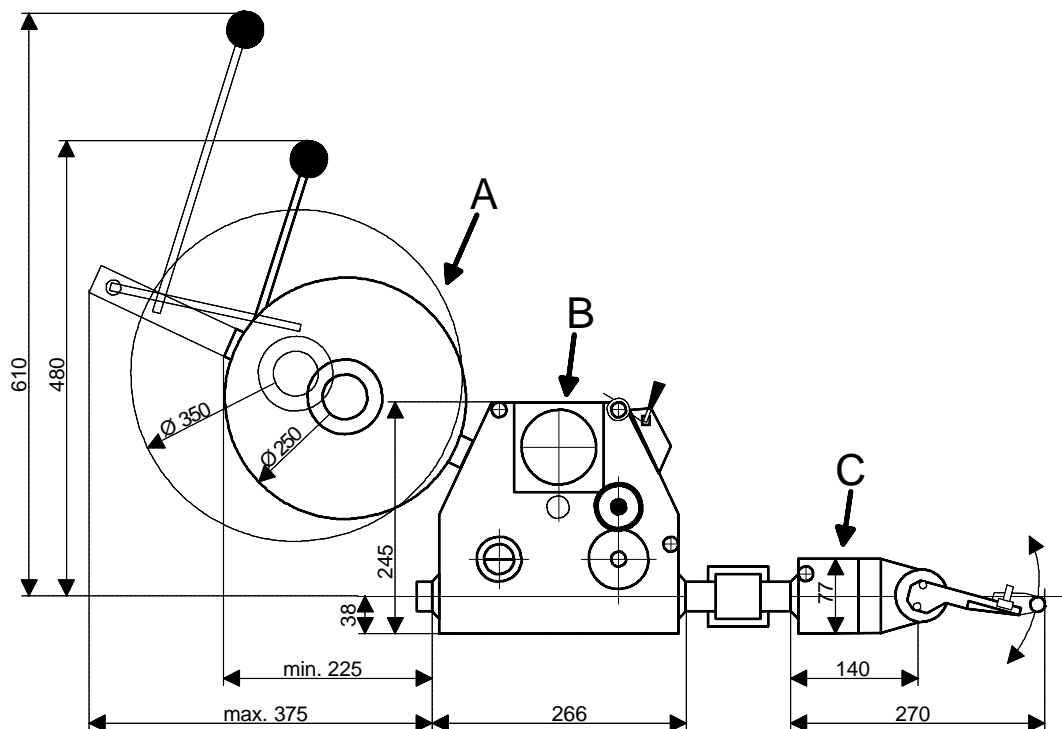

A) Abwickler
B) Vorzugwerk
C) Klappenadapter
D) Für Deckelmontage

A) Unwinder
B) Traction unit
C) Flap adapter
D) For lid dismantling

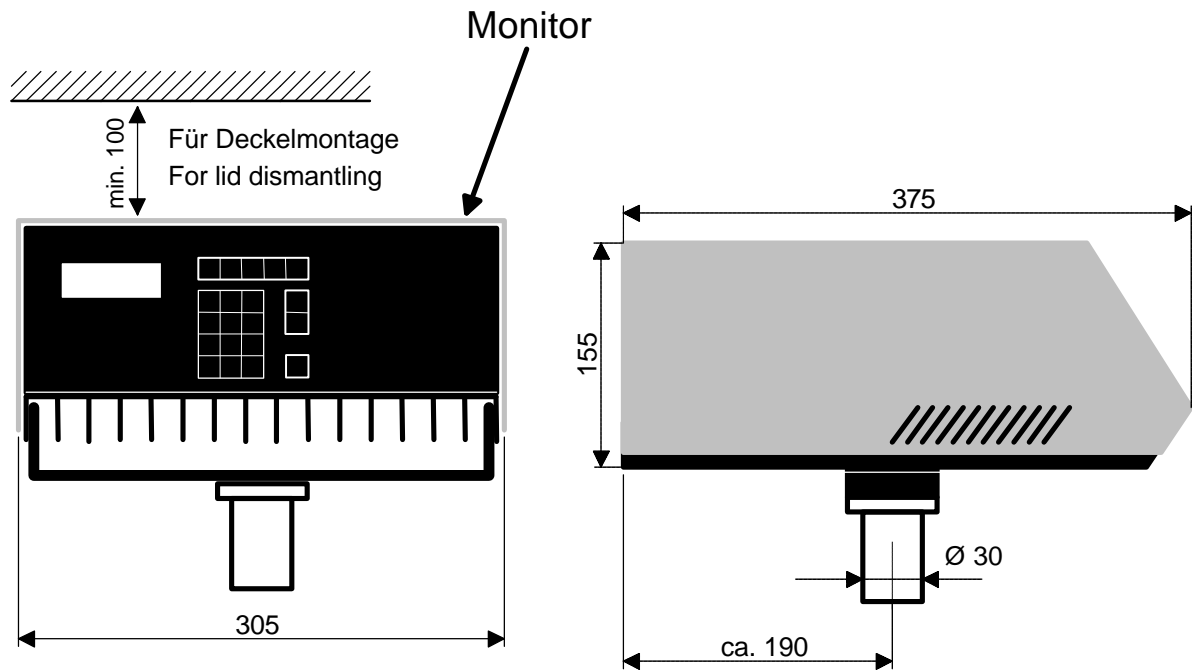

18 Troubleshooting

18.1 Troubleshooting Collamat 8600

The troubleshooting will proceed along the paperpath. See following figure:

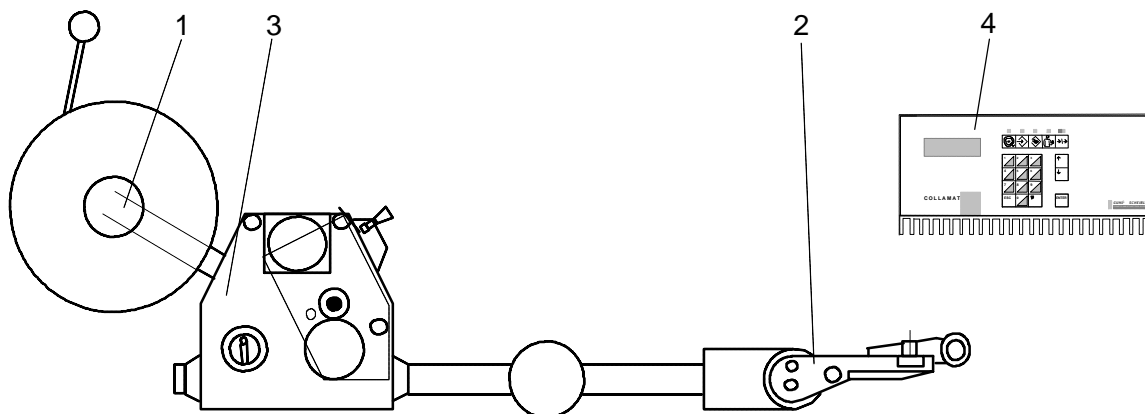

Unit

1. Unwinder 2. Adapter 3. Traction unit 4. Monitor

1. Unwinder troubleshooting		
SYMPTOM	DIAGNOSIS	ACTION
Labels peel off at the dancer roll	Dancer roll diameter is too small	Change the standard roll against a roll with enlarged diameter
Dancer arm is bent and breaks	Dancer arm material is too weak or too thin (older Collamat)	Use new dancer arms (C3600/C6600/C8600)
Flange of the fixed disk breaks	Material defect, wrong type of aluminum	Replace flange against new series flange
Unwinder blocks	Disk touches the diskbrake	Shift the disk on the unwindershaft away from the diskbrake
	Shaft is blocked	Lubricate the bearings on the shaft
	Diskbrake does not open	Readjust the diskbrake
The torsion spring comes off the knurled knob	Wrong kind of torsion spring	Exchange the torsion spring against an according torsion spring
The unwinder tends to fall off while side labeling	Paper roll too heavy	Mount a separate clamp to the module rail to stiffen the unwinder rail
Dancer roll gets shaky	Shaft screw is loose	Fix the screw (use perhaps Locktite)
Dancer bearing gets shaky	Module rail is worn out by the dancer axle	Replace module rail and dancer axle

1. Unwinder troubleshooting		
SYMPTOM	DIAGNOSIS	ACTION
Paperweb falls off in side labeling applications	Missing side labeling kit	Mount the side labeling kit to the Collamat

2. Adapter troubleshooting		
SYMPTOM	DIAGNOSIS	ACTION
Labels run through	Roll-up cable is broken	Replace roll-up cable
	Label sensor cable is broken	Replace label sensor cable
	IR transmitter cable is broken	Replace transmitter cable
	IR transmitter LED broken	Replace transmitter print
	Label sticks below the label sensor	Remove the sensor and clean it properly
	IR light guide is blind	Replace IR light guide
	Label scanner position not over the label	Place the scanner over the label transport path
Pressing roll is worn out	Roll is pressed too hard to the goods	Lift the labeler, reduce the adapter spring force
Pressing roll axle hangs/is bent down	Fixing hex nut is loose	Retighten the hex nut (apply Loctite)
	Pressing roll axle is bent or broken	replace the axle
Adapter flap gets shaky	Lever fixing screw is loose	Remove the flange holding the two knurled rolls and retighten the lever
Labels are not dispensed straight forward	Peeling bar is worn out	Replace the peeling bar
Labels form bubbles	Labeling speed too fast	Reduce labeling speed
Labels form wrinkles	Labeling speed too slow	Increase labeling speed
	Labeler is misaligned to product transport	Realign the labeler
Adapter tilts down while labeling	Backing paper not threaded between the adapter roll pair	Tread the paperweb correctly between the adapter roll pair
Paperweb breaks behind the peeling bar	Lateral paperguides hurt the paperweb	Enlarge the space between the paperguides

2. Adapter troubleshooting		
SYMPTOM	DIAGNOSIS	ACTION
Paperweb breaks behind the peeling bar	Paperbrake set too hard	Reduce the braking force
	Peeling bar is too sharp	Use peeling bar with a bigger radius
		Add Teflon tape around the peeling bar
	Peeling bar touches the goods	Lift the labeler/adapter away from the goods
	Paperweb is perforated	Use unperforated paperwebs or use a peeling bar with bigger radius

3. Traction unit troubleshooting		
SYMPTOM	DIAGNOSIS	ACTION
Pressure roller is shaky	Pressure roller shaft is broken	Replace pressure roller shaft
Traction roller turns in the wrong direction	Problems in the rewinder clutch	Release the breaking force of the rewinder
	Feltdisks are worn out	Replace the felt disks
	Parallel pin inside the rewinder shaft is blocked	Release the parallel pin clean and lubricate it
Potentiometer settings have no effect	DATA-HOLD-switch active	Switch it off
Motor is very hot	No fault	This is normal for a stepper motor
Motor makes high frequent noise	No fault	This is normal for a stepper motor
Traction roller is shaky while power on	Pin at the front flange of the traction roller is broken or worn out	Exchange pin or if necessary exchange the complete traction roller
	The toothed belt roll or the locking plate is broken	Exchange the toothed belt roll or exchange the locking plate and fix it tight
At higher labeling speed the motor stalls	Too much friction of the paperweb	Check the paperbrake
		Add Teflon tape to the peeling bar
At higher labeling speed the motor stalls	Too much friction of the paperweb	Reduce all friction of the paperweb where possible
		Check the unwinder dancer
Paperweb breaks behind the paperbrake	Lateral paperguides hurt the paperweb	Enlarge the space between the paperguides
	Paperbrake set too hard	Reduce the braking force

5. Monitor troubleshooting		
SYMPTOM	DIAGNOSIS	ACTION
Motor is dead, Display is not illuminated	No mains connected to trafo	Check for correct main connection
		Check main fuse
		Check internal trafo wiring
Motor is dead, Display is illuminated, LED1 is off	No power on the motor supply	Check internal trafo wiring
	Fuse F1 (4AT) is blown	Replace fuse F1 (4AT)
Motor is dead, Display is illuminated, LED1 is on. Motor driver probably not working. Check motor driver LEDs	If LED1 (green) is on is on, motor driver is OK	see next symptom
	If LED2 is on there is a short of the motor phases	Check the wires between the motor driver and the mains filter board and the motor connector
	If LED3 is on there is too high temperature	Check the cause
	If LED4 is on there is overvoltage	Check the voltage selector and the trafo wiring
	If LED5 is on there is undervoltage	Check the voltage selector and the trafo wiring
Motor is dead, Display is illuminated, motor driver seems to be OK	Motor connector is not plugged in properly	Plug it in properly
	The wires between the motor driver and the mains filter board and the motor connector are not OK	reconnect the wires between the motor driver and the mains filter board and the motor connector
	Filter components on the mains filter board are broken	Replace the mains filter board
	Motor wires not connected properly inside the motor	Rewire the motor wires properly
Motor turning direction is wrong	Wrong setting of the MOTOR DIRECTION setting	Change the setting on the monitor
Motor turning direction is wrong	Wrong motor connector wiring	Reconnect motor wires according to the Technical Handbook
Motor turning direction is wrong	Wrong motor cable wiring	Reconnect motor cable according to the Technical Handbook
Collamat labels only at 3m/min	Monitor speed setting is set to default FIXED SPEED	Change the setting to meet the requirements
Motor makes noise and shakes. It does not turn correctly	Faulty motor driver	Replace the motor driver
	Missing connection of one motor wire	Connect motor wires according to the Technical Handbook

5. Monitor troubleshooting		
SYMPTOM	DIAGNOSIS	ACTION
No action after power on but motor is under power	Missing good scanner signal	Try LABEL JOG in the LABELING MODE menu
	Monitor stopped	Set it to RUN
	Monitor set to NONSTOP SLAVE	Set it to the according mode
The mains fuse often blows	The mains impedance is too low	Use an extended power cord
	The mains fuse is too weak	Use a slow blow (timed) mains fuse
The 5V, 12V and 24V LEDs are all off	Fuse F2 is blown, probably result of a short of the 24V in the peripheral units	Check the peripheral units, replace the fuse (10AT)
The 12V LED is off	Probably result of a short of the 12V in the peripheral units	Check the peripheral units
The 5V LED is off	Probably result of a short in the 5V of the processor supply. Disconnect the control panel	If LED still off: replace the interface board
		Check the ribbon cable
		If LED now ON: replace the control panel
The monitor frequently resets	Software error	Clear all programs using the password 4147 while power on procedure
	Electro magnetic interference RMI	Check the environment and wiring. All cables must be shielded in this case

18.2 Trouble shooting checklist

Machine-Type:		Ser.No. Monitor:	Ser.No. Labeler:
Ser.No Control panel:	Software-Version:	Ser.No. Motordriver:	Ser.No. Interfaceboard:
Environment	Mains voltage:	Frequency Hz:	Temperature °C:
	Humidity %:	Interference level (Burst):	Interference level ESD (Static):
Labels	Width:	Length:	Gap:
	Thickness:	Transparency:	Material:
Paperweb	Width:	Thickness:	Transparency:
Goods	Kind:	Material:	Shape:
	Length:	Width:	High:
	Speed m/min	Length in transportation:	Distance:
Labeler	Speed m/min:	Pieces / min.:	Measuring:
Settings	Predispensing:	Position mm:	Suppression:
	TCY value:	Label length:	Suppression:
Special:			
Machine- environment	Goodstransport:	Feeder:	Taker:
	Other machines around:		
Peripheral units	1	2	3
Screening	Mains cable:	Sensorcables:	
ESD-Phenomena	Description:		
Description of the malfunctions:	Accumulation	frequent: repeated:..... sec spontaneous:	
Date / ev. date and time of the last disturbances:			
Comments:			
Disturbance registered by Name: Date:			

Please make a copy of this list before using it.